

## Multi-Position Cased Coils Cooling and Heat Pump Compatible Cooling capacity 30–60 kBTU/h

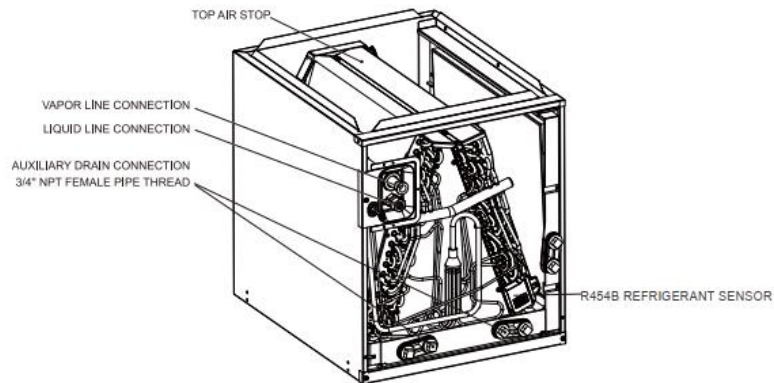
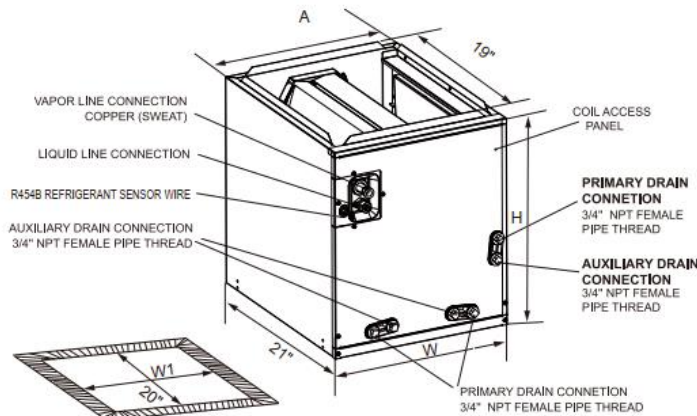

MODELS	Unit Dimensions IN. [mm]					(LBS. [kg])
	UNIT HEIGHT "H"	UNIT WIDTH "W"	SUPPLY DUCT "A"	"W1"	LIQUID LINE/ VAPOR LINE	
MCPM3036AN1DH	20 [508]	14-1/2 [368]	13 [330]	13-1/2 [343]	3/8 / 3/4	44 [20]
MCPM3036BN1DH	20 [508]	17-1/2 [445]		16-1/2 [419]	3/8 / 3/4	
MCPM3036CN1DH	20 [508]	21 [533]		20 [508]	3/8 / 3/4	
MCPM3642BN1DH	26 [660]	17-1/2 [445]		16-1/2 [419]	3/8 / 3/4	
MCPM3642CN1DH	26 [660]	21 [533]		20 [508]	3/8 / 3/4	59 [27]
MCPM3642DN1DH	26 [660]	24-1/2 [622]		23-1/2 [597]	3/8 / 3/4	64 [29]
MCPM4248BN1DH	30 [762]	17-1/2 [445]		16-1/2 [419]	3/8 / 3/4	73 [33]
MCPM4248CN1DH	30 [762]	21 [533]		20 [508]	3/8 / 3/4	73 [33]
MCPM4248DN1DH	30 [762]	24-1/2 [622]		23-1/2 [597]	3/8 / 3/4	75 [34]
MCPM4860CN1DH	30 [762]	21 [533]		20 [508]	3/8 / 3/4	82 [37]
MCPM4860DN1DH	30 [762]	24-1/2 [622]		23-1/2 [597]	3/8 / 3/4	86 [39]

# Specifications

	<b>MCPM3036AN1DH</b>	<b>MCPM3036BN1DH</b>	<b>MCPM3036CN1DH</b>	<b>MCPM3642BN1DH</b>
	Multiple position	Multiple position	Multiple position	Multiple position
	13x19	16x19	19-1/2 x19	16x19
	30,000/36,000	30,000/36,000	30,000/36,000	36,000/42,000
	Tube & Fin	Tube & Fin	Tube & Fin	Tube & Fin
	Aluminum	Aluminum	Aluminum	Aluminum
	9/32	9/32	9/32	9/32
	3/8	3/8	3/8	3/8
	3/4	3/4	3/4	3/4
	21x14-1/2x20	21x17-1/2x20	21x21x20	21x17-1/2x26
Packed dimensions (W Hx D) (in.)	25x17-11/16x 22-1/4	24-15/16x20-5/8x 22-1/4	24-15/16x24-3/16x 22-1/4	24-15/16x20-5/8x 28-1/8
	45	47	49	57
	54	57	55	64

	<b>MCPM3642CN1DH</b>	<b>MCPM3642DN1DH</b>	<b>MCPM4248BN1DH</b>	<b>MCPM4248CN1DH</b>
	Multiple position	Multiple position	Multiple position	Multiple position
	19-1/2x19	23x19	16x19	19-1/2 x19
	36,000/42,000	36,000/42,000	42,000/48,000	42,000/48,000
	Tube & Fin	Tube & Fin	Tube & Fin	Tube & Fin
	Aluminum	Aluminum	Aluminum	Aluminum
	9/32	9/32	3/8	3/8
	3/8	3/8	3/8	3/8
	3/4	3/4	3/4	3/4
	21x21x26	21x24-1/2x26	21x17-1/2x30	21x21x30
Packed dimensions (W Hx D) (in.)	24-15/16x24-3/16 x28-1/8	24-15/16 x27-9/16 x28-1/8	24-15/16 x 20-5/8 x 32-5/16	24-15/16 x 24-3/16 x32-5/16
	59	64	73	73
	66	70	79	79

	<b>MCPM4248DN10H</b>	<b>MCPM4860CN10H</b>	<b>MCPM4860DN10H</b>
	Multiple position	Multiple position	Multiple position
	23 x19	19-1/2 x19	23 x19
	42,000/48,000	48,000/60,000	48,000/60,000
	Tube & Fin	Tube & Fin	Tube & Fin
	Aluminum	Aluminum	Aluminum
	3/8	3/8	3/8
	3/8	3/8	3/8
	3/4	3/4	3/4
	21x24-1/2x30	21x21x30	21x24-1/2x30
Packed dimensions (W HxD) (in.)	24-15/16 x 27-9/16 x32-5/16	24-15/16 x 24-3/16 x32-5/16	24-15/16 x 27-9/16 x32-5/16
	75	82	86
	82	88	93

## Features

Equipped with a refrigerant sensor, suitable for R454b system .

UL 60335 2-40 and AHRI certificated.

High efficiency and energy saving, AHRI energy efficiency certificated

Multi-position installation accommodated a variety of installation scenarios .

Broad cooling range from 5°F to 120°F.

Optional factory installed Thermostatic Expansion Valve .

All aluminum coil for corrosion-resistance.

100% insulation, reduces operating sound and enhance thermal insulation.

Perfect match with Midea MGV gas furnace, no need extra kit for R454b system.

**North American HVAC Products Ltd.**

**HA-SA202404V1**

Add.: 5118 N Fraser Wy, Burnaby, BC V5J 0H1

Tel: 604-430-8496 info@nahvac.com www.nahvac.com



Midea reserves the right to change the specifications of the product, and to withdraw or replace products without prior notification or public announcement.

Midea is constantly developing and improving its products.