

## ACRYLIC



Model AC91

**Model AC90**  
(Right-hand Plumbing)

**Model AC91**  
(Left-hand Plumbing)

**Length:** 61" (1549 mm)

**Width:** 32 1/2" (826 mm)

**Height:** 83 1/2" (2121 mm)

**Shipping Weight:** 209 lbs (95 kg)

**Water to Overflow:** 40 gallons (185 Litres)

**Minimum Water Capacity:** 31 gallons (140 Litres)

**Materials:** Manufactured from a one-piece acrylic sheet, reinforced with fiberglass.

The Ballintine bath/shower is economical, easy to maintain and leak proof with an integral dometop. It fits into a 5' opening and is popular for new construction or as a multi-piece unit for renovations.

**Standard Features:**

- Easy to clean high gloss surface
- Chip and mar resistant
- Moulded-in floor pattern
- Lumbar support backrest
- Upper and lower toiletry shelves
- Clear acrylic grip rail

**Options:**

- Light Kit

**Colours:**

- Standard: White, Almond (Bone) or Biscuit.
- Optional: Kohler Colours

**Other Configurations:**

- 3-piece knockdown (KD)
- Whirlpool (CMJ6)

All products manufactured by Hytec are covered by a comprehensive five-year limited warranty from the date of sale to the original owner. See the Hytec Bathing Fixtures List Price Book for further details.

**Hytec Plumbing Products**

(Division of Kohler Canada Co.)

4150 Spallumcheen Dr, Armstrong BC V0E 1B6

Ph. (800) 871-8311 (250) 546-3196 Fax (250) 546-3170



Model AC90/91

ACRYLIC

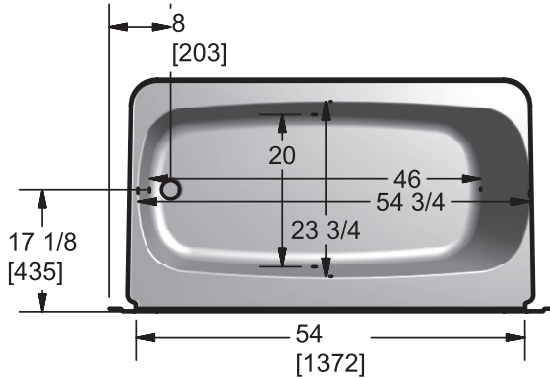
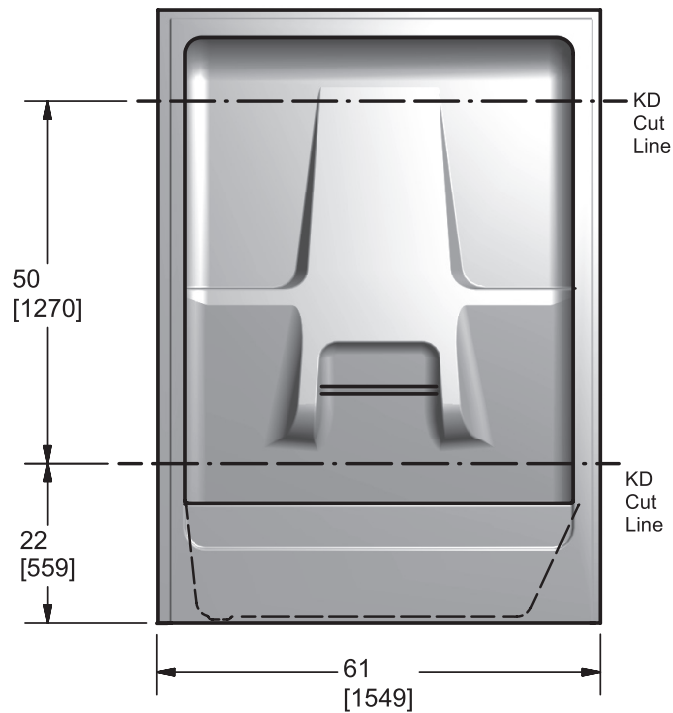
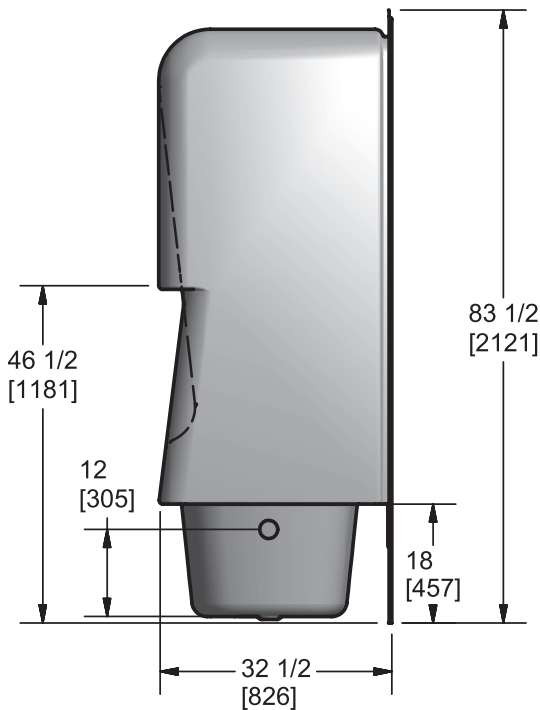

Measurement tolerances ± 1/4" (6.3 mm)

All bathing fixtures comply with the applicable Canadian Standards.

For installation procedures, please refer to instructions included with each unit.

This sheet approximately describes products and equipment manufactured or supplied by Hytec Plumbing Products. Because of ongoing efforts to improve both design and quality, products and equipment actually furnished may differ without prior notice.



**Hytec Plumbing Products**

(Division of Kohler Canada Co.)

4150 Spallumcheen Dr, Armstrong BC V0E 1B6

Ph. (800) 871-8311 (250) 546-3196 Fax (250) 546-3170