

CYCLONE® MXi MODULATING

MODULATING BURNER ADVANCES THE CYCLONE TO HIGHER LEVELS OF EFFICIENCY

The full line of A. O. Smith Cyclone MXi condensing water heaters has been designed to provide years of dependable service and feature industry leading technology. Models are available from 120,000 to 500,000 BTU/h and all deliver thermal efficiencies of 95% and higher. The unique helical coil heat exchanger limits weld joints for optimal service life while maximizing heat transfer.

Cyclone is the industry leader in high efficiency commercial water heating. The current MXi modulating models adjust firing rate to the specific demand further increasing efficiency and money savings.

INTELLIGENT CONTROL SYSTEM WITH TOUCH SCREEN DISPLAY AND iCOMM™ CONNECTIVITY ON-BOARD*

- Exclusive A. O. Smith designed colour touch display control system
- Provides detailed water heater status information
- Precise temperature control adjustable from 90 to 180 degrees
- Built-in diagnostics
- Run history information
- Intelligent Demand Response (IDR) feature senses large water draws and automatically adjusts the differential set point. This feature increases the hot water available when it is needed the most.

*Cyclone MXi models manufactured March 1, 2018 to present come standard with iCOMM Wi-Fi connectivity on-board. Remotely monitor and adjust the water heater via the A. O. Smith app. No charge connectivity using Wi-Fi or Ethernet connection.

SUBMERGED COMBUSTION CHAMBER, WITH HELICAL HEAT EXCHANGER COIL

- Positioned in center of tank, surrounded by water to virtually eliminate radiant heat loss from chamber
- Direct spark ignition
- Spiral heat exchanger keeps hot burner gases swirling, uses centrifugal force to maximize efficiency of heat transfer to water in tank
- Spiral heat exchanger reduces lime scale from forming on water-side surfaces, which maintains energy efficiency over time

POWERED ANODES STANDARD ON ALL MODELS

- Provides long-lasting tank protection in varying water conditions
- Powered anodes are non-sacrificial

- Automatically adjusts output needed to properly protect the tank

PERMAGLAS® ULTRA COAT™ GLASS LINING

- Glass coating is applied using a liquid slush coating technique to ensure uniform coating
- Heat exchanger coil is glassed both externally and internally for optimum protection

MECHANICAL VENTING VERSATILITY

- Conventional power venting or direct venting
- Vents vertically or through a sidewall
- Front located exhaust and condensate connections allow for easy install and access
- Vents with low cost PVC Schedule 40 intake and exhaust pipe. Approved for optional CPVC Schedule 40, Polypropylene and AL29-4C stainless steel vent materials
- Direct-vent intake and exhaust pipe can terminate separately outside building or through single opening, using concentric vent assembly

- Canadian installations require ULC S636 PVC, CPVC, Polypropylene or AL29-4C stainless steel pipe for exhaust

HIGH EFFICIENCY MODULATING PRE-MIX POWERED BURNER

- Down-fired pre-mix burner provides optimum efficiency and quiet operation
- Top-mounted burner position prevents condensation from affecting burner operation

3-YEAR LIMITED TANK / 1-YEAR LIMITED PARTS WARRANTY

- For complete warranty information, consult written warranty or go to hotwater.com



BTH-120(A) THROUGH BTH-500(A)
MODEL SHOWN:
BTH-199(A) SERIES 300/301





Commercial Gas Water Heaters

OTHER FEATURES:

SPACE-SAVING DESIGN FOR INSTALLATION FLEXIBILITY

- Easy-to-remove top cover for convenient access to serviceable parts
- 0" installation clearances on sides and rear, 1-1/2" installation clearance on top
- Handhole cleanout allows easy access to tank interior for cleaning
- 0" clearance to combustibles, approved for installation on combustible floors

CODES AND STANDARDS

- CSA certified and ASME rated T&P relief valve
- Maximum hydrostatic working pressure: 160 psi
- All models are design certified by Underwriters Laboratories (UL), Inc., to ANSI Z21.10.3 - CSA 4.3 Standards
- Meets the thermal efficiency and standby loss requirements of NRCan and current edition ASHRAE/IES 90.1
- Design Certified by Underwriters Laboratories to NSF standard 5 for 180°F (62°C) water
- ASME tank construction optional on 120-250 model sizes

VENT REQUIREMENTS FOR BTH 120(A) - 250(A)

NUMBER OF 90° ELBOWS INSTALLED	3 INCH PIPE	4 INCH PIPE
	MAXIMUM FEET (METERS)	MAXIMUM FEET (METERS)
One (1)	45 feet (13.7 meters)	115 feet (35 meters)
Two (2)	40 feet (12.2 meters)	110 feet (33.5 meters)
Three (3)	35 feet (10.7 meters)	105 feet (32 meters)
Four (4)	30 feet (9.1 meters)	100 feet (30.5 meters)
Five (5)	N/A	95 feet (29 meters)
Six (6)	N/A	90 feet (27.4 meters)

VENT REQUIREMENTS FOR BTH 300(A) - 500(A)

NUMBER OF 90° ELBOWS INSTALLED	4 INCH PIPE	6 INCH PIPE
	MAXIMUM FEET (METERS)	MAXIMUM FEET (METERS)
One (1)	65 feet (19.8 meters)	115 feet (35 meters)
Two (2)	60 feet (18.2 meters)	110 feet (33.5 meters)
Three (3)	55 feet (16.8 meters)	105 feet (32 meters)
Four (4)	50 feet (15.2 meters)	100 feet (30.5 meters)
Five (5)	45 feet (13.7 meters)	95 feet (29 meters)
Six (6)	40 feet (12.2 meters)	90 feet (27.4 meters)

GAS PRESSURE REQUIREMENTS

MODEL NUMBER	MANIFOLD PRESSURE		MINIMUM SUPPLY PRESSURE		MAXIMUM SUPPLY PRESSURE	
	NATURAL GAS	PROPANE GAS	NATURAL GAS	PROPANE GAS	NATURAL GAS	PROPANE GAS
BTH-120(A)	0"W.C. (0 kPa)	0"W.C. (0 kPa)	3.5"W.C. (1.10 kPa)	8.5"W.C. (2.12 kPa)	14"W.C. (3.49 kPa)	14"W.C. (3.49 kPa)
BTH-150(A)	0"W.C. (0 kPa)	0"W.C. (0 kPa)	3.5"W.C. (1.10 kPa)	8.5"W.C. (2.12 kPa)	14"W.C. (3.49 kPa)	14"W.C. (3.49 kPa)
BTH-199(A)	0"W.C. (0 kPa)	0"W.C. (0 kPa)	3.5"W.C. (1.10 kPa)	8.5"W.C. (2.12 kPa)	14"W.C. (3.49 kPa)	14"W.C. (3.49 kPa)
BTH-250(A)	0"W.C. (0 kPa)	0"W.C. (0 kPa)	3.5"W.C. (1.10 kPa)	8.5"W.C. (2.12 kPa)	14"W.C. (3.49 kPa)	14"W.C. (3.49 kPa)
BTH-300(A)	0"W.C. (0 kPa)	0"W.C. (0 kPa)	4.8"W.C. (1.19 kPa)	8.5"W.C. (2.12 kPa)	14"W.C. (3.49 kPa)	14"W.C. (3.49 kPa)
BTH-400(A)	0"W.C. (0 kPa)	0"W.C. (0 kPa)	4.8"W.C. (1.19 kPa)	8.5"W.C. (2.12 kPa)	14"W.C. (3.49 kPa)	14"W.C. (3.49 kPa)
BTH-500(A)	0"W.C. (0 kPa)	0"W.C. (0 kPa)	4.8"W.C. (1.19 kPa)	8.5"W.C. (2.12 kPa)	14"W.C. (3.49 kPa)	14"W.C. (3.49 kPa)

Depending on the installed equivalent length, and/or the number of appliances connected, the supply gas line size may need to be increased beyond the minimum required size.

BTH 120-250

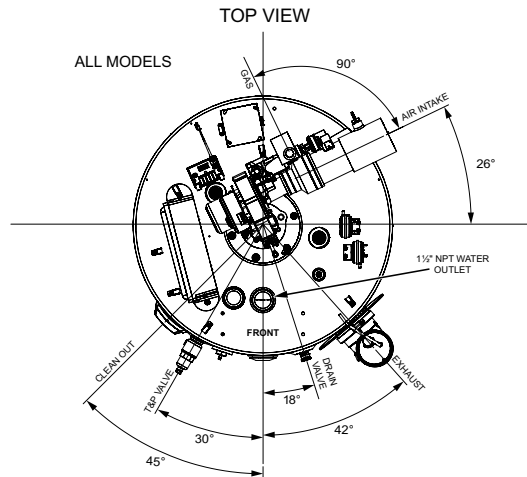
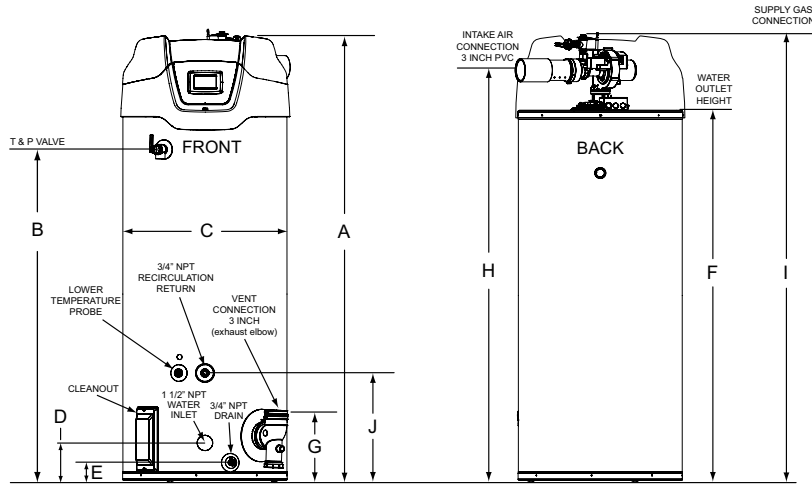

* Center line of water outlet on top of the water heaters is approximately 7 inches from the front edge of the water heater

MODEL NUMBER	APPROX. CAPACITY		DIMENSIONS										LB/KG	APPROX. SHIPPING WEIGHT STD	APPROX. SHIPPING WEIGHT ASME
			A	B	C	D	E	F	G	H	I	J			
BTH-120(A)	Gallons	60	55 1/2	35	27 3/4	6 5/16	3	42 1/4	11 1/4	48 1/2	53 1/2	18 1/4	lb	460	490
	Litres	227	141	88.9	70.5	16	7.62	107.32	28.6	123.2	135.9	46.36	kg	208	220
BTH-150(A)	Gallons	100	76 1/2	56 3/8	27 3/4	6 5/16	3	64	11 1/4	70	75 1/2	18 1/4	lb	523	553
	Litres	379	194.9	143.2	70.5	16	7.62	162.6	28.6	177.8	191.8	46.36	kg	237	251
BTH-199(A)	Gallons	100	76 1/2	56 3/8	27 3/4	6 5/16	3	64	11 1/4	70	75 1/2	18 1/4	lb	523	553
	Litres	379	194.9	143.2	70.5	16	7.62	162.6	28.6	177.8	191.8	46.36	kg	237	251
BTH-250(A)	Gallons	100	76 1/2	56 3/8	27 3/4	6 5/16	3	64	11 1/4	70	75 1/2	18 1/4	lb	523	553
	Litres	379	194.9	143.2	70.5	16	7.62	162.6	28.6	177.8	191.8	46.36	kg	237	251

Electrical characteristics-120V-60Hz A.C., 5.0 A

"A" in model represents ASME construction

Propane gas models available

Dimensions and specifications subject to change without notice in accordance with our policy of continuous product improvement.

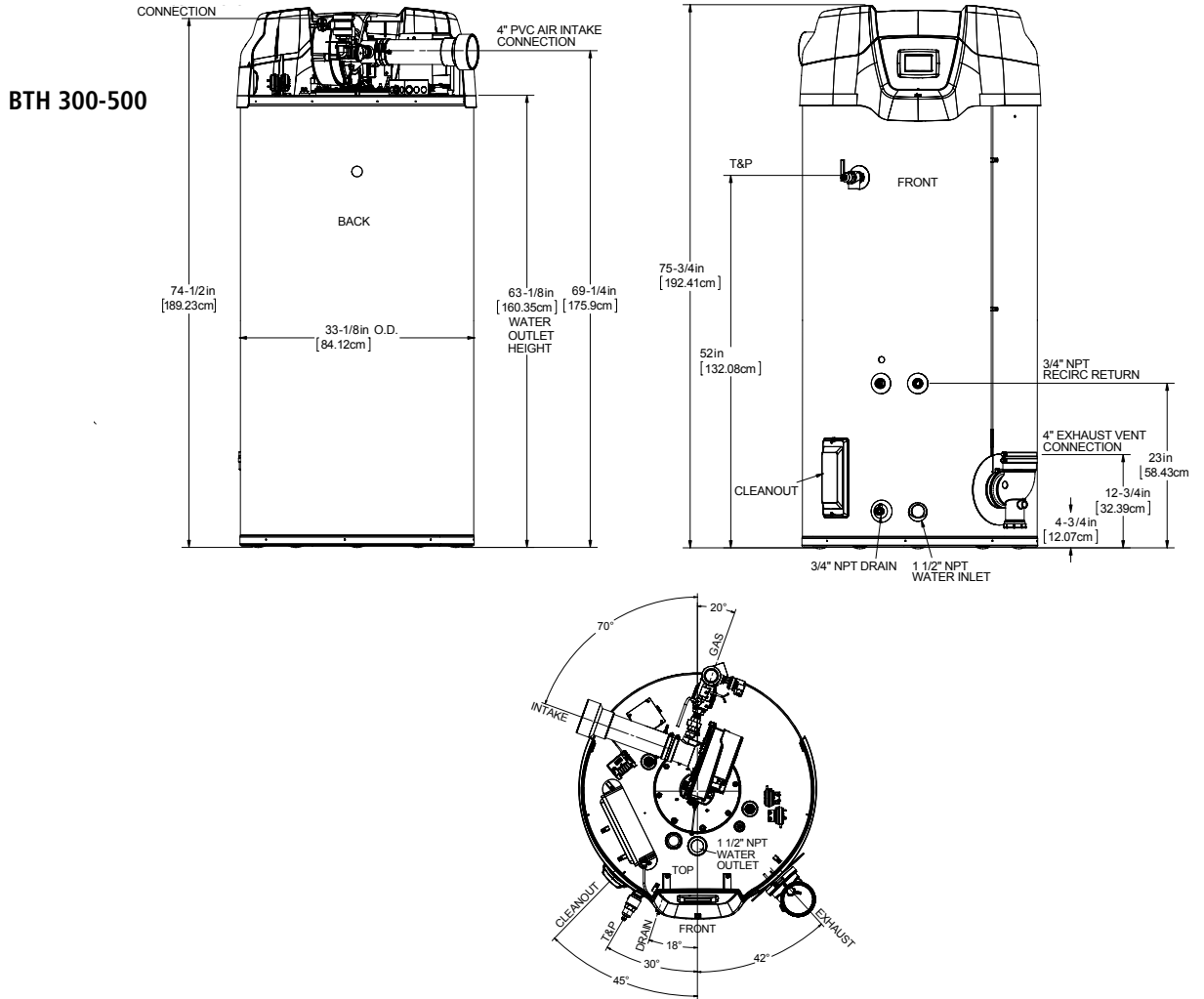

MODEL NUMBER	APPROX. CAPACITY		DIMENSIONS										LB/KG	APPROX. SHIPPING WEIGHT STD	APPROX. SHIPPING WEIGHT ASME
			A	B	C	D	E	F	G	H	I	J			
BTH-300(A)	Gallons	119	75 3/4	52	33 1/8	4 3/4	4 3/4	63 1/8	12 3/4	69 1/4	74 1/2	23	lb	855	855
	Litres	450.96	192.41	132.08	84.12	12.07	12.07	160.35	32.39	175.9	189.23	58.43	kg	387	387
BTH-400(A)	Gallons	119	75 3/4	52	33 1/8	4 3/4	4 3/4	63 1/8	12 3/4	69 1/4	74 1/2	23	lb	855	855
	Litres	450.96	192.41	132.08	84.12	12.07	12.07	160.35	32.39	175.9	189.23	58.43	kg	387	387
BTH-500(A)	Gallons	119	75 3/4	52	33 1/8	4 3/4	4 3/4	63 1/8	12 3/4	69 1/4	74 1/2	23	lb	855	855
	Litres	450.96	192.41	132.08	84.12	12.07	12.07	160.35	32.39	175.9	189.23	58.43	kg	387	387

Electrical characteristics-120V-60Hz A.C., 5.0 A

"A" in model represents ASME construction

Propane gas models available

Dimensions and specifications subject to change without notice in accordance with our policy of continuous product improvement.

RECOVERY CAPACITY

MODEL NUMBER	TYPE OF GAS	INPUT		THERMAL EFFICIENCY
		BTU/h	KW	
BTH-120(A)	Natural/Propane	120,000	35	95%
BTH-150(A)	Natural/Propane	150,000	44	98%
BTH-199(A)	Natural/Propane	199,900	58	97%
BTH-250(A)	Natural/Propane	250,000	73	96%
BTH-300(A)	Natural/Propane	300,000	88	96%
BTH-400(A)	Natural/Propane	399,900	117	95%
BTH-500(A)	Natural/Propane	499,900	146	95%

MODEL NUMBER	U.S. GALLONS/HR AND LITRES/HR AT TEMPERATURE RISE INDICATED													
	APPROX. CAPACITY	°F	30°F	40°F	50°F	60°F	70°F	80°F	90°F	100°F	110°F	120°F	130°F	140°F
		°C	17°C	22°C	28°C	33°C	39°C	44°C	50°C	56°C	61°C	67°C	72°C	78°C
BTH-120(A)	60 U.S. Gals.	GPH	461	345	276	230	197	173	154	138	126	115	106	99
	227 Litres	LPH	1743	1308	1046	872	747	654	581	523	475	436	402	374
BTH-150(A)	100 U.S. Gals.	GPH	594	445	356	297	255	223	198	178	162	148	137	127
	379 Litres	LPH	2248	1686	1349	1124	963	843	749	674	613	562	519	482
BTH-199(A)	100 U.S. Gals.	GPH	783	588	470	392	336	294	261	235	214	196	181	168
	379 Litres	LPH	2965	2224	1779	1483	1271	1112	988	890	809	741	684	635
BTH-250(A)	100 U.S. Gals.	GPH	970	727	582	485	416	364	323	291	264	242	224	208
	379 Litres	LPH	3670	2753	2202	1835	1573	1376	1223	1101	1001	918	847	786
BTH-300A	119 U.S. Gals.	GPH	1164	873	698	582	499	436	388	349	317	291	269	249
	450.96 Litres	LPH	4405	3304	2643	2202	1888	1652	1468	1321	1201	1101	1017	944
BTH-400A	119 U.S. Gals.	GPH	1535	1151	921	767	658	576	512	460	419	384	354	329
	450.96 Litres	LPH	5810	4358	3486	2905	2490	2179	1937	1743	1585	1453	1341	1245
BTH-500A	119 U.S. Gals.	GPH	1919	1439	1151	959	822	720	640	576	523	480	443	411
	450.96 Litres	LPH	7263	5448	4358	3632	3113	2724	2421	2179	1981	1816	1676	1556

Recovery capacities are based on AHRI rated thermal efficiencies.
For ASME Construction add an "A" to the end of the model number ex: BTH-120A.

STORAGE CAPACITY

MODEL NUMBER	U.S. GALLONS	LITRES
BTH 120	60	227
BTH 150	100	379
BTH 199	100	379
BTH 250	100	379
BTH 300	119	450.96
BTH 400	119	450.96
BTH 500	119	450.96

GAS LINE CONNECTION SIZE

MODEL	SERIES	NATURAL GAS	PROPANE GAS
BTH 120	300/301	3/4" NPT	3/4" NPT
BTH 150	300/301	3/4" NPT	3/4" NPT
BTH 199	300/301	3/4" NPT	3/4" NPT
BTH 250	300/301	3/4" NPT	3/4" NPT
BTH 300	300/301	1-1/2" NPT	1-1/2" NPT
BTH 400	300/301	1-1/2" NPT	1-1/2" NPT
BTH 500	300/301	1-1/2" NPT	1-1/2" NPT

OPTIONAL KITS

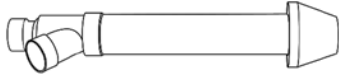

OPTIONAL CONCENTRIC VENT KITS

- BTH-120 - 250 vent kit p/n 100111100
- BTH-300 - 500 vent kit p/n 100113124

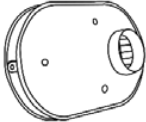

OPTIONAL LOW PROFILE TERMINATION VENT KITS

- 3" Flush Mount Vent Kit p/n 100187887
- 4" Flush Mount Vent Kit p/n 100187888
- 6" Flush Mount Vent Kit p/n 100187889

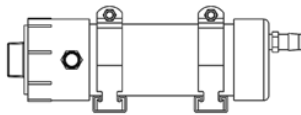

OPTIONAL CONDENSATE NEUTRALIZATION KITS

- BTH-120-199 kit p/n 100112380
- BTH-250-500 kit p/n 100112381

COMMON VENTING KITS FOR UP TO 3 WATER HEATERS (ONE KIT PER WATER HEATER REQUIRED)

KIT	DESCRIPTION
100227396	PVC Common Vent Kit, 120 – 250 Models
100223775	PVC Common Vent Kit, 300 – 500 Models
100227395	Polypropylene Common Vent Kit, 120 -250 Models
100223774	Polypropylene Common Vent Kit, 300 - 500 Models

Installations must comply with all federal, provincial and local codes.
See kit instructions and corresponding water heater manual for detailed installation instructions and additional information.
50 Feet maximum equivalent length of straight pipe common vent and elbows
NOTE: Order 1 kit for each water heater.
See the Common Vent Kit manual or spec sheet for detailed information.

LEAK DETECTION KIT*

*Cyclone® MXi models manufactured March 13, 2019 and later are compatible with a leak detection kit accessory.

- BTH 120-500 kit p/n 100302557

SPECIFICATION

(Natural or Propane) gas water heater(s) shall be A. O. Smith Cyclone MXi model # _____ or equal, minimum 95% thermal efficiency, a storage capacity of _____ gallons, an input rating of _____ BTUs per hour, a recovery rating of _____ gallons per hour (gph) at 100°F rise and a maximum hydrostatic working pressure of 160 psi. Water heater(s) shall: 1. Modulating gas burner that automatically adjusts the input based on demand. 2. Powered anodes that are non sacrificial and maintenance free. 3. Have seamless glass-lined steel tank construction, with glass lining applied to all water-side surfaces after the tank has been assembled and welded; 4. Meets the thermal efficiency and/or standby loss requirements of NRCAN and current edition of ASHRAE/IES 90.1; 5. Have foam insulation and a CSA Certified and ASME rated T&P relief valve; 6. Have a down-fired power burner designed for precise mixing of air and gas for optimum efficiency, requiring no special calibration on start-up; 7. Be approved for 0" clearance to combustibles.

The control shall be an integrated solid-state temperature and ignition control device with integral diagnostics, graphic user interface, fault history display, and shall have digital temperature readout. 1. All models are design certified by Underwriters Laboratories (UL), Inc., according to ANSI Z21.10.3 - CSA 4.3 standards governing storage type water heaters; 2. Meet the thermal efficiency and standby loss requirements of NRCAN and current edition ASHRAE/IES 90.1.

120K-250K BTU Input: For Standard Power Venting: Water heater(s) shall be suitable for power venting using a (3" or 4") _____ diameter PVC pipe for a total distance of (50 ft or 120 ft.) _____ equivalent feet of vent piping. For Power Direct Venting: Water heater(s) shall be suitable for power direct venting using a (3" or 4") _____ diameter PVC pipe for a total distance of (50 ft or 120 ft.) _____ equivalent feet of vent piping and (50 ft. or 120 ft.) _____ equivalent feet of intake air piping.

300K - 500K BTU Input: For Standard Power Venting: Water heater(s) shall be suitable for standard power venting using a (4" or 6") _____ diameter PVC pipe for a total distance of (70 ft. or 120 ft.) _____ equivalent feet of vent piping. For Power Direct Venting: Water heater(s) shall be suitable for power direct venting using a (4" or 6") _____ diameter PVC pipe for a total distance of (70 ft or 120 ft.) _____ equivalent feet of vent piping and (70 ft. or 120 ft.) _____ equivalent feet of intake air piping.

Operation of the water heater(s) in a closed system where thermal expansion has not been compensated for (with a properly sized thermal expansion tank) will void the warranty.

For Technical Information call 888-599-2837. A. O. Smith Enterprises Ltd. reserves the right to make product changes or improvements without prior notice.