



# Installation Guide

**Ultra-Rib<sup>®</sup>**

**Ultra-X2<sup>™</sup>**

**Enviro-Tite<sup>®</sup>**

**Ring-Tite<sup>®</sup>**

M U N I C I P A L   S Y S T E M S

PVC SEWER PIPE & FITTINGS

100 mm - 1,500 mm (4" - 60")



**IPEX**

by **alixis**

We build tough products for tough environments<sup>®</sup>

## TABLE OF CONTENTS

<b>STARTING THE JOB</b> .....	<b>4</b>
Receiving and Handling .....	4
Unloading .....	5
Cold Weather Handling .....	6
Stockpiles .....	6
Weathering Resistance .....	6
Distribution Along Trench .....	7
Loading Transfer Trucks .....	8
Gaskets .....	8
Excavation .....	8
Line and Grade .....	9
Trench Width .....	9
<b>INSTALLATION</b> .....	<b>10</b>
Trench Zones .....	10
Embedment Materials .....	11
Selection of Embedment Materials .....	12
Preparation of Trench Bottom .....	12
Trench Boxes .....	13
Lowering Pipe Into Trench .....	13
Dimensions .....	14
Assembly of Pipe .....	18
Lubricant .....	20
Curved Sewers .....	20
Field Cut Assembly .....	23
Manhole Connections .....	24
Service Connections .....	25
Sewer Laterals .....	28
Riser Problems Demand Special Attention .....	28
Backfilling and Tamping .....	29
Tamping Equipment .....	30
<b>TESTING OF SEWERS</b> .....	<b>31</b>
Joint Tightness Testing .....	31
Deflection Testing .....	33
Videos .....	36

**SPECIAL APPLICATIONS . . . . .36**

Installing Pipe Through Casings . . . . .	36
Percent (%) Deflection of Ring-Tite, Enviro-Tite DR35, Ultra-Rib and Ultra-X2 Pipe . . . . .	40
Percent (%) Deflection of IPEX Centurion Pipe . . . . .	40
Deep Burial . . . . .	42
Shallow Burial . . . . .	42
Tie-In Connections . . . . .	42
Repairs . . . . .	43
Solvent-Weld Pipe & Fittings . . . . .	45

**SOLVENT CEMENTING . . . . .45**

Principles of Solvent Cementing . . . . .	45
Solvent Cementing Instructions . . . . .	46
Handling . . . . .	46
Storage Conditions . . . . .	46
Safety Precautions . . . . .	46
Cold Weather . . . . .	47
Preparation . . . . .	47
Initial Set Time Schedule . . . . .	51
Joint Cure Schedule . . . . .	51

**ADDITIONAL INFORMATION . . . . .52**

Standards . . . . .	52
Abbreviations . . . . .	53
Addresses . . . . .	54
Unit Conversion . . . . .	55

# IPEX PVC SEWER PIPE INSTALLATION GUIDE FOR RING-TITE, ENVIRO-TITE, ULTRA-RIB AND ULTRA-X2

## INTRODUCTION

This book was written especially for the installer and for those who direct the actual handling and installation of IPEX Ring-Tite, Enviro-Tite, Ultra-Rib and Ultra-X2 PVC Gravity Sewer Pipes. This guide is not intended to supply all necessary design information nor to assume the responsibility of the Engineer (or other designer) in establishing procedures best suited to individual job conditions in order to attain satisfactory performance.

Engineers, superintendents, contractors, foremen and pipe laying crews will find this guide contains many helpful suggestions. This guide will also be of help in determining needs when ordering pipe and fittings.

## STARTING THE JOB

### Receiving and Handling

Each pipe and fitting shipment should be inspected with care upon its arrival. The pipe and fittings were carefully loaded at the factory using methods acceptable to the carrier and it is their responsibility to deliver it in good order. **It is the duty of the receiver to ensure that there has been no loss or damage in transit.**

The tally sheet or bill of lading which accompanies each shipment provides a complete list of all items included.

Check the load against the tally sheet and report any errors to the transportation agent immediately. Be sure to have proper notations made on the delivery receipt.

Below is a checklist to follow when receiving shipments from carriers:

1. Make an overall examination of the load. If intact, ordinary inspection while unloading should be enough to make sure the pipe has arrived in good condition.
2. If the load has shifted or shows rough treatment, each piece must then be carefully inspected for damage.
3. Check total quantities of each item against tally sheet (pipe, gaskets, fittings, lube, etc.).
4. Any damaged or missing items must be noted on delivery receipt and returned to the transportation company.
5. Notify the carrier immediately and make claim in accordance with their instructions.
6. Do not dispose of any damaged material. The carrier will notify you of proper procedure to follow.
7. Shortages and damaged material are not automatically reshipped. If replacement material is needed, reorder through your distributor or IPEX representative.

## Unloading

It is the customer's decision and responsibility on how PVC sewer pipe and fittings are unloaded in the field.

When unloading units, follow these instructions carefully:

- (a) Remove restraints from the top unit loads; typically being 32 mm (1-1/4") straps.
- (b) If needed, remove all 25 mm x 100 mm (1" x 4") boards across the top and down the sides of the units.
- (c) Remove the strapping only on the bundles of pipe being unloaded, and remove one unit at a time.
- (d) Use a forklift (or front end loader with forks) to remove each top unit separately. Remove the rear units first. Do not slide the equipment forks against the underside of pipe in a pallet. This may damage the pipe by abrasion.
- (e) If a forklift is not available, a spreader bar on top and nylon straps capable of handling the load may be used. The straps must be spaced approximately 2.5 m (8.2') apart and be looped under the unit. Cables should be cushioned with a rubber hose or other soft material to prevent abrasion to the pipe.
- (f) During the removal and handling, be sure that the units do not hit anything. Severe impact could cause damage, particularly during very cold weather installations.
- (g) Do not
  - i. Handle units with chains or single cables.
  - ii. Attach cables to unit frames for lifting.
- (h) Units should be:
  - i. Stored and placed on level ground.
  - ii. Stacked no more than two units high.
  - iii. Protected by dunnage (scrap wood) the same way they were loaded on the truck. The dunnage must support the weight of all units so that pipe lengths do not carry the weight of the unit loaded above them.
- (i) To unload lower units, repeat the above process (items A through H).
- (j) For Ultra-Rib pipe, if there are broken ribs for a continuous length of 300 mm (12") or more, that pipe length should not be used.

Preferred unloading is by units. If unloading equipment is not available, the pipe may be removed individually by cutting the bands securing the top tiers to those below. Care should be taken to ensure that the pipe is not dropped or damaged. Since the bands are tightly bound, the pipe may have a tendency to move when a band is cut. Make sure the truck is parked on level ground and that no one is standing near either side of the truck in case a length should roll off. Do not stand on the banded pipe while cutting the band.

### Cold Weather Handling

Extra care should be taken in handling during cold weather. As the temperature drops below freezing, the flexibility and impact resistance of PVC pipe is reduced.

Pipe at the bottom of a bundle may become out of round slightly due to the weight of the pipe stacked above it. At normal temperatures, this situation will correct itself soon after the load is removed. Under freezing conditions, the recovery to initial roundness may take several hours.

### Stockpiles

Stockpiles should always be built on a flat base. If mechanical equipment is being used to handle the unit, bearing pieces provide an excellent base. If unloading by hand, secure two timbers for a base. Set them on a flat area spaced the same distance as a factory load. Nail stop blocks at each end. Build up the stockpile in the same manner as it was stacked for shipment, transferring dunnage and chock blocks from the load to the stockpile.

Individual lengths of pipe should be stacked in piles no higher than 1.5 m (5').

### Weathering Resistance

It should be noted that when PVC pipe is stored outside and exposed to prolonged periods (i.e. six months or more) of direct sunlight, an exterior discoloration may occur.

This process is simply a hardening of the outer thousandths of an inch layer of vinyl. Physical properties such as pipe stiffness and tensile strength of PVC pipe are unaffected by surface discoloration. However, impact resistance may be reduced slightly. As a result, extra care should be used

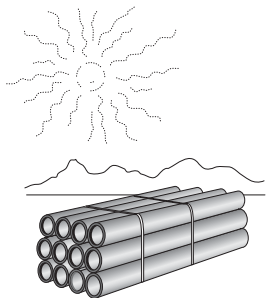

during installation and backfilling. It should be noted that degradation does not continue after PVC pipe has been buried.

A method of protecting PVC during extended exposure to sunlight is to cover it with an opaque material such as canvas. Air circulation should be provided under the protective cover. For above ground installations, application of a water-based latex paint will be effective protection against continuous sunlight exposure.

### Distribution along Trench

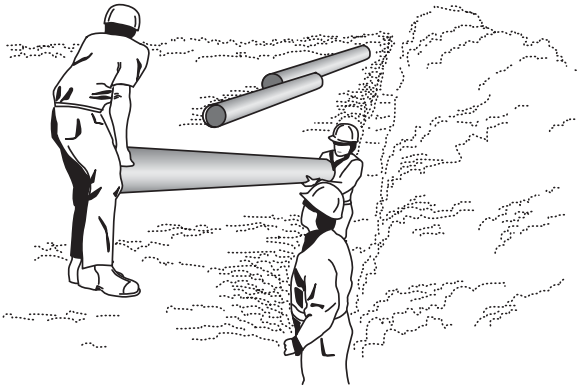

In stringing out PVC pipe, keep these points in mind:

1. Lay pipe as near the trench as possible to avoid excess handling.
2. If the trench is open, it is advisable to string pipe on the side away from excavated soil wherever possible. This will allow pipe to be moved easily to the edge of the trench for lowering into position.
3. If the trench is not yet open, find out to which side excavated soil will be thrown. Then, string out pipe on the opposite side.
4. Place pipe in such a manner to protect it from traffic and heavy equipment. Also, safeguard it from the effects of any blasting which may be done.
5. Direct sunlight may cause the exposed side of the pipe to heat up creating a bow in the pipe. Should this occur, rotate the cool side towards the sun or place the pipe in the shade to alleviate the curving effect. Leaving the pipe in units will minimize bowing of PVC pipe due to heat from the sun.
6. It is common practice to string pipe with bell ends pointing upgrade.



## Loading Transfer Trucks

Use trucks with long bodies so that pipe lengths do not overhang more than 600 mm (24"). Make certain that the truck bed is smooth, without cross-strips, bolt heads, or other protrusions which could damage the pipe.

Place the first layer with the bell ends overhanging; avoid sliding the pipe and abrading it. Subsequent layers can be slid into place. All bell ends should overhang the layer below.

Short body trucks may be used if fitted with racks which properly support the pipe in a horizontal position, with supports spaced every meter (3') or less along the pipe lengths. Pad contact areas to avoid damage to the pipe.

## Gaskets

IPEX Ring-Tite, Enviro-Tite, Ultra-Rib, Ultra-X2 and Centurion sewer pipes are provided with factory installed rubber gaskets eliminating the need for field installation. For Ring-Tite, Enviro-Tite and Centurion pipe, the gasket is placed inside the bell end to accommodate a smooth-walled spigot for assembly. With Ultra-Rib and Ultra-X2, the gasket is positioned on the spigot exterior for assembly into the smooth-surface interior of the bell.

Gaskets standardly supplied with IPEX PVC sewer pipe are made from the commonly used elastomer, SBR. Other gasket materials such as neoprene or nitrile are available should the gasketed joint require any special chemical resistance. Consult IPEX for recommendations.

## Excavation

As a general rule, do not open the trench too far ahead of pipe laying. Avoiding long stretches of opened trench will often reduce your costs by:

- (a) reducing pumping and sheeting requirements
- (b) minimizing the possibility of flooding the trench
- (c) reducing caving caused by ground water
- (d) helping to avoid frozen trench bottom and backfill
- (e) lowering safety hazard risks to workers and traffic

For sewer projects involving extremely deep cuts, Ring-Tite, Enviro-Tite and Ultra-Rib are available in shorter lengths. Contact IPEX for details on availability and delivery for these special orders.

## Line and Grade

Abrupt directional changes for sewer lines are often accomplished using manholes. Besides being an access chamber to the line, the manhole acts as a directional junction box for sewer pipe laid in straight lines.

The grade to which the pipe is to be laid is generally specified on the project drawings. Rather than suggesting a minimum grade to be used at all times with IPEX sewer pipe, it is recommended that the grade be sufficient to provide a minimum velocity of 0.6 m/s (2.0 fps). This will ensure that the flow is self-cleansing at all times inside the pipe.

## Trench Width

The width of the trench at the top of the pipe should allow for proper placement and compaction of the haunching materials. Generally, the minimum trench width should be 300 mm (12") greater than the outside diameter of the pipe, with a minimum value of 450 mm (18") at all times.

For a rigid pipe, keeping the trench width narrow is important since the load imposed upon the pipe is a function of the trench width. However, for flexible pipe, the maximum load on the pipe is the "prism load" which is the weight of the soil column directly above the pipe. Thus, precautions in keeping the trench narrow are unnecessary for a PVC pipe installation. The key is to compact the haunching material out to the undisturbed trench walls. More details on proper installation are contained in the following section.

## INSTALLATION

An understanding of flexible conduit terminology is essential for the installer. The soil class and density realized in the bedding, haunching and initial backfill zones are important factors in achieving a satisfactory installation of PVC pipe.

Much of the installation information can also be found in Canadian Standards Association (CSA) Standard B182.11, entitled, "Recommended Practice for the Installation of Thermoplastic Drain, Storm and Sewer Pipe and Fittings" or ASTM Standard D2321, entitled, "Underground Installation of Thermoplastic Pipe for Sewers and Other Gravity Flow Applications."

### Trench Zones

The following figure has been prepared to illustrate the various zones used with flexible pipe terminology.

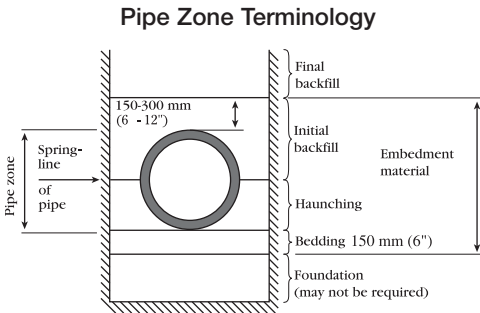

**Foundation** – A foundation is required when the trench bottom is unstable. Any foundation that will support a rigid pipe without causing loss of grade or structural breakage will be more than adequate for PVC pipes.

**Bedding** – The bedding directly underneath the pipe is required only to bring the trench bottom up to grade. It should not be so thick or soft that the pipe will settle and lose grade. The sole purpose of the bedding is to provide a firm, stable and uniform support of the pipe. A bedding thickness of 100 mm (4") is most times sufficient. The engineer may wish to increase the bedding to 150 mm (6") for ledge rock foundations.

**Haunching** – This area is the most important in terms of limiting the vertical deflection of the flexible pipe. Pipe support is obtained in the haunch zone by compacting soil in both directions away from the pipe to the undisturbed trench walls.

**Initial Backfill** – This zone begins above the springline to a level 150 mm (6") to 300 mm (12") above the top of the pipe. Compaction here will give little additional side support to PVC pipe, but may be required to maintain stability of any above ground surfaces (i.e. roads or sidewalks).

**Note:** The particle size recommended for the three zones described above should not exceed 38 mm (1.5") for Ring-Tite, Enviro-Tite, Ultra-Rib, Ultra-X2 and Centurion.

**Final Backfill** – The remainder of the trench fill above the initial backfill provides no support for a PVC pipe and should be free of stones 150 mm (6") and larger. Compaction may be required for reasons other than support of the PVC pipe since this zone is very significant in supporting the above ground surfaces (i.e. roads or highways).

### Embedment Materials

Some general rules about all soils to be used in a buried pipe-line trench include that they must be free of sharp objects, sticks, large clumps, frozen material, organic materials and boulders.

Most of the soils commonly found can be classified into one of the following categories, which are referenced from ASTM D2487.

**Class 1:** Angular, 6 mm to 38 mm (1/4" – 1-1/2") graded stone, including a number of fill materials such as coral, slag, cinders, crushed stone or crushed shells.

**Class 2:** Coarse sands and gravels with a maximum particle size of 38 mm (1-1/2"), including various graded sands and gravels containing small percentages of fines, generally granular and non-cohesive.

**Class 3:** Fine sand and clayey gravels, including fine sands, sand-clay mixtures and gravel-clay mixtures.

**Class 4:** Silt, silty clays, and clays including inorganic clays and silts of medium to high plasticity and liquid limits.

**Class 5:** Includes organic soils such as frozen earth, debris and other foreign materials. These materials are not recommended for use in the bedding, haunch or initial backfill zones.

**Note:** The performance of a flexible conduit does not depend only on the class of embedment materials used, but more importantly, on the density achieved in compaction of the haunching material.

## Selection of Embedment Materials

Soil to be used in the pipe zone should be capable of maintaining the specified soil density. For example, if a coarse material such as Class 1 is used for bedding the pipe, it should also be used in the haunch zone to the springline of the pipe. Otherwise, side support may be lost due to migration of the Class 2, 3 or 4 material into the bedding.

When selecting the embedment materials, ensure that native soil migration from the trench walls cannot occur. A well-graded compacted granular material will prevent this condition from occurring. In trenches subject to inundation, the granular material should be compacted to a minimum of 85% Standard Proctor Density.

## Preparation of Trench Bottom

Preparation of the trench bottom is the starting point for a satisfactory and safe sewer pipe installation. The trench bottom should be smooth and free from large stones, clumps of dirt, and any frozen material as approved by the engineer. It is economical on most sewer installations to undercut the trench bottom by machine and bring it up to grade by use of granular material.

If the bedding material chosen is a loose granular such as sand, the pipe can be laid directly on it. If the bedding is a hard, compacted material, excavation for the bells (bell holes) should be provided so that the pipe is uniformly supported along the entire length.

Coarse sand, crushed stone or shell often is the most economical granular material because compaction is easily obtained. With all types of soil, voids should be eliminated under and around the lower half of the pipe by working in granular materials by shovel slicing.

Native backfill may be used for the trench bottom providing the soil is free of large stones, hard lumps and debris, and can be properly compacted by tamping. Ensure that the fill does not fit the Class 5 description.

In rocky trenches, place a minimum 100 mm (4") layer of select bedding material to provide a cushion for the pipe. The rock foundation must first be excavated to at least 100 mm (4") below the final grade of the pipe bottom. Any buried pipe, regardless of pipe material, that rests directly on rock may be subject to eventual breakage under the weight of soil and/or live loads.

When an unstable trench bottom is encountered and appears to be unable to support the pipe properly, the engineer may insist

that the bottom be excavated and refilled to pipe grade with an approved foundation and bedding material. This layer should be compacted to a minimum 85% Standard Proctor Density.

## Trench Boxes

It is good safety practice to use movable trench boxes whenever possible while installing pipe in a below ground trench. The trench box serves as a lateral support to protect workers from possible cave-ins. They are often a requirement of local labor codes.

In order not to compromise the integrity of a PVC pipe installation, there are essentially two options available when using a trench box:

1. Set the box directly on the trench foundation after having bottom corner sections of the box removed on each side. This will permit proper placement and compaction of bedding material in the pipe zone. The box should be regularly moved along in the direction of the excavation with the cut-away section being at the back end (as shown below).

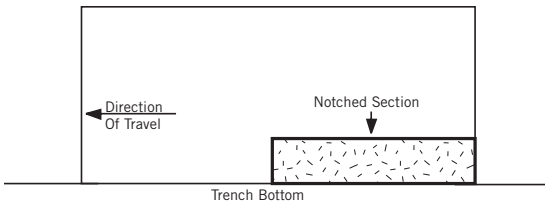

2. A full profile box may be used but only if it is set on ledges or shelves made in the sidewalls of the trench. These ledges should be located above the springline of the pipe. This will create a subditch condition within the trench, and will ensure optimal compaction around the PVC pipe. A full profile box will also be effective if suspended from the top of the trench by cross beams or side-wheels.

## Lowering Pipe into Trench

PVC sewer pipe in sizes up to 375 mm (15") diameter are capable of being handled and lowered into the trench by hand. Larger pipe should be lowered using ropes and skids or an excavator bucket with slings. Do not kick or throw PVC pipe into the trench.

Pipe and fittings should be inspected for defects or damage prior to lowering into the trench. Any defective or damaged pipe or fittings should be repaired or replaced. All foreign matter should be removed from the pipe interior before lowering for usage. For Ultra-Rib Pipe, the maximum permitted continuous length of broken ribs is 300 mm (12").

## Dimensions

### 1. Ring-Tite and Enviro-Tite

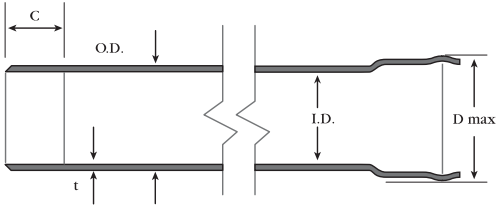

- where, O.D. = average outside diameter  
 I.D. = average inside diameter  
 t = minimum wall thickness  
 Dmax = approximate outside diameter of the bell  
 C = insertion depth distance

Note: Bell profiles are for information only. Actual profiles may vary

**Enviro-Tite available in all DR28 sizes & DR35 from 100 - 375 mm.**

Pipe Size		O.D.		I.D.		t		D <sub>max</sub>		C	
mm	in	mm	in	mm	in	mm	in	mm	in	mm	in
DR28											
100	* 4	107.1	4.22	99.0	3.90	3.8	0.15	135	5.31	71	2.8
125	* 5	143.3	5.64	132.5	5.22	5.1	0.20	173	6.81	72	2.8
150	* 6	159.4	6.28	147.3	5.80	5.7	0.22	191	7.52	89	3.5
DR35											
100	4	107.1	4.22	100.7	3.96	3.1	0.12	133	5.24	71	2.8
125	5	143.3	5.64	134.6	5.30	4.1	0.16	171	6.73	72	2.8
150	6	159.4	6.28	149.6	5.89	4.6	0.18	189	7.44	89	3.5
200	8	213.4	8.40	200.4	7.89	6.1	0.24	245	9.65	100	3.9
250	10	266.7	10.50	250.5	9.86	7.6	0.30	310	12.20	115	4.5
300	12	317.5	12.50	298.1	11.74	9.1	0.36	364	14.33	125	4.9
375	15	388.6	15.30	365.1	14.37	11.1	0.44	442	17.40	145	5.7
450	18	475.0	18.70	448.1	17.56	13.6	0.53	550	21.65	286	11.3
525	21	560.0	22.05	528.3	20.71	16.0	0.63	640	25.20	317	12.5
600	24	630.0	24.80	594.4	23.36	18.0	0.71	700	27.56	343	13.5
675	27	710.0	27.95	669.9	26.26	20.3	0.80	800	31.50	343	3.5
750	30	812.8	32.00	763.8	30.07	23.2	0.91	926	36.46	356	4.0
900	36	972.8	38.30	914.4	36.00	27.8	1.09	1108	43.62	406	6.0
1050	42	1130.3	44.50	1062.0	41.81	32.3	1.27	1265	49.80	406	16.0
1200	48	1290.3	50.79	1216.6	47.89	36.9	1.45	1435	56.5	457	18.0
1350	54	1462.0	57.55	1378.5	54.27	41.8	1.64	1617	63.7	508	20.0
1500	60	1564.9	61.61	1475.5	58.08	44.7	1.76	1728	68.1	560	22.0

## 2. Ultra-Rib

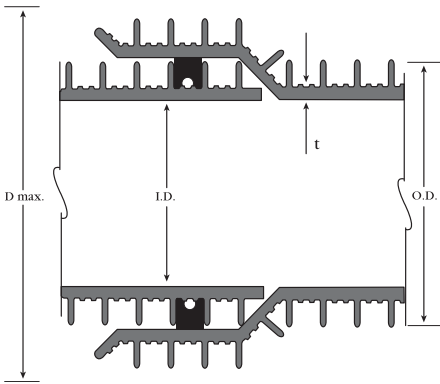

where,

- O.D. = average outside diameter of barrel
- I.D. = average inside diameter
- t = minimum waterway wall thickness
- Dmax = approximate outside diameter of bell

Pipe Size		O.D.		I.D.		t		D <sub>max</sub>	
mm	in	mm	in	mm	in	mm	in	mm	in
200	8	224	8.8	200	7.87	2.20	0.09	248	9.8
250	10	280	11.0	251	9.88	2.30	0.09	311	12.2
300	12	333	13.1	298	11.73	2.60	0.10	371	14.6
375	15	408	16.1	365	14.37	2.80	0.11	453	17.8
450	18	497	19.6	448	17.64	3.30	0.13	556	21.9
525	21	584	23.0	527	20.75	4.06	0.16	665	26.2
600	24	660	26.0	597	23.50	4.58	0.18	724	28.5



## 3. Ultra-X2

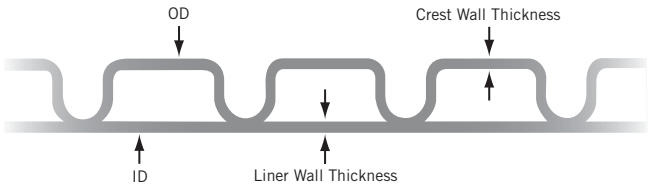

Nominal Pipe Size		O.D.		I.D.		Crest Wall Thickness		Liner Wall Thickness		Insertion Force lbf
mm	in	mm	in	mm	in	mm	in	mm	in	
750	25.53	816.6	32.15	749.2	29.50	3.7	0.15	5.6	0.22	985
900	35.43	984.6	38.76	901.4	35.49	3.3	0.13	4.6	0.18	1000

#### 4. IPEX Centurion

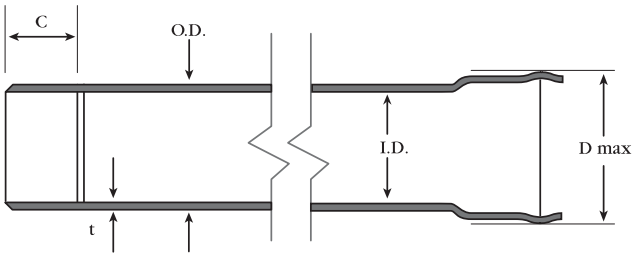

where, O.D. = average outside diameter

I.D. = average inside diameter

t = minimum wall thickness

Dmax = approximate outside diameter of the bell

C = insertion depth distance

**Note:** Bell profiles are for information only. Actual profiles may vary.

Pipe Size		O.D.		I.D.		t		D <sub>max</sub>		C	
mm	in	mm	in	mm	in	mm	in	mm	in	mm	in
DR41											
600	24	655	25.8	623	24.5	16.0	0.63	752	29.6	330	13.0
750	30	813	32.0	773	30.4	19.8	0.78	917	36.1	368	14.5
900	36	973	38.3	925	36.4	23.7	0.93	1089	42.9	393	15.5
1050	42	1130	44.5	1075	42.3	27.5	1.09	1255	49.4	406	16.0
1200	48	1290	50.8	1227	48.3	31.5	1.24	1424	56.1	432	17.0
1350	54	1462	57.6	1392	54.8	35.7	1.40				
1500	60	1565	61.6	1488	58.6	38.1	1.50				

#### DR51

600	24	655	25.8	630	24.8	12.8	0.50	745	29.3	330	13.0
750	30	813	32.0	781	30.7	15.9	0.63	909	35.8	368	14.5
900	36	973	38.3	935	36.8	19.1	0.75	1080	42.5	393	15.5
1050	42	1130	44.5	1086	42.8	22.2	0.87	1240	48.8	406	16.0
1200	48	1290	50.8	1240	48.8	25.3	1.00	1409	55.5	432	17.0
1350	54	1462	57.6	1405	55.3	1.13	28.7				
1500	60	1565	61.6	1503	59.2	1.21	30.7				

**Note:** The installation recommendations presented in this booklet for Ring-Tite and Enviro-Tite are generally valid for IPEX Centurion pipe used for gravity sewer applications.

For specific recommendations, contact your local IPEX sales office.

## Assembly of Pipe

Ring-Tite, Enviro-Tite, Ultra-Rib, Ultra-X2 and Centurion pipe are assembled in the form of a bell and spigot gasketed joint. For Ring-Tite, Enviro-Tite pipe and Centurion pipe, the gasket is in place in the interior of the bell while the spigot is factory-beveled for easy insertion. Ultra-Rib and Ultra-X2 differ by having the gasket positioned on the spigot exterior, between the second and third ribs, for insertion into a smooth-interior bell. Assembly procedures are virtually identical.

## Assembly Steps

1. Ensure that the bell interior and spigot exterior are clean and free from foreign material that could prevent an effective seal between the bell and spigot.

**Note:** All Ring-Tite, Enviro-Tite and Centurion PVC pipe is shipped with a chamfer on the end of the spigot. If there is no chamfer, follow the example of a factory-made spigot and machine a suitable chamfer using a beveling tool, hand rasp, disk cutter or router.

2. Apply IPEX lubricant to the pipe as follows:
  - (a) **Ring-Tite, Enviro-Tite and Centurion Pipe** – Apply lube to the spigot end only. The coating of lube should extend back 50 to 75 mm (2 to 3") from the spigot edge and should cover the entire circumference. The bell interior need not be lubricated.
  - (b) **Ultra-Rib and Ultra-X2 Pipe** – Lube should be applied to the entire circumference of the bell interior to half of the bell depth. A thin layer of lube should also be applied to the gasket exterior on the spigot end.

The lube may be applied using a brush, cloth, glove, sponge or pad.

3. Insert the spigot end into the bell until the Ring-Tite, Enviro-Tite or Centurion spigot comes in contact with the rubber ring, or for Ultra-Rib and Ultra-X2, until the spigot gasket contacts the bell end.
4. While keeping the lengths in proper alignment, brace the bell and push the spigot into the bell. **The spigot should be inserted until the reference mark on the pipe barrel is even with the edge of the bell.**

**Note:** If undue resistance is felt to the assembly, the joint should be disassembled, cleaned and remade in accordance with the above methods. Dislodged gaskets can be re-installed on the spigot of Ultra-Rib, and Ultra-X2 or in the bell of all IPEX Ring-Tite, and Enviro-Tite except for pipe with the pinched O-ring gasket. If excessive resistance still exists upon reassembly, **do not attempt to force the assembly.** Contact IPEX immediately for assistance.

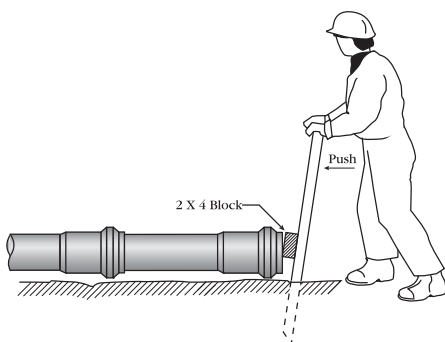

Pipe can normally be assembled by hand or by bar and block for sizes up to 375 mm (15"). For larger sizes, it may be necessary to install the pipe using methods such as lever pullers, hydraulic jacks or the backhoe bucket.

When such mechanical means are used, the assembly effort should not be applied directly to the edge of the pipe. A two-by-four or a plank should be placed between the backhoe bucket and the pipe edge. The use of the excavator bucket has the disadvantage that the machine operator is unable to clearly see the pipe installation. A helper should assist by observing the reference mark and signalling the operator when the assembly is complete.

**Note:** Insertion depths may vary among different pipe manufacturers. As a result, care should be taken when assembling IPEX pipe with another brand of PVC pipe. The insertion depth of the other brands bell should be measured and marked on the IPEX spigot. If assembling the spigot of another brand of pipe into an IPEX bell, refer to Dimension C on page 14 for proper insertion depths of the IPEX bells.

**CAUTION:** Over-assembly of a PVC sewer pipe joint may cause one or both of the problems below:

- (a) Joint flexibility may be lost which may cause a leak in the case of uneven settlement.
- (b) The inside diameter may be reduced enough to appear as an over-deflection on a deflection mandrel test.

### Lubricant

To assemble IPEX PVC sewer pipe, the installer should only use IPEX lubricant. The correct amount of lubricant can be calculated using the chart below. If adverse conditions are encountered, such as extreme cold or high water table, extra lubricant must be used.

### LUBRICANT USAGE - Joints Per Container

Nominal Pipe Size		Average Number of Joints per Container					
mm	in	250 g	516 g	1 kg	4 kg	11 kg	23 kg
100	4	17	34	70	280	805	1,610
125	5	14	28	56	225	645	1,290
150	6	10	20	40	160	460	920
200	8	7	14	28	110	320	640
250	10	5	10	20	80	230	460
300	12	3	7	14	55	160	320
375	15	2	4	8	32	87	175
450	18	1	2	4	16	45	90
500	20	1	2	3	12	35	70
525	21	1	2	3	12	35	70
600	24	1	1	2	8	22	45
675	27		1	2	6	17	35
750	30			1	4	12	25
900	36				3	7	15
1050	42				2	5	10
1200	48				1	3	7
1350	54				1	2	5
1500	60					1	3

How to use the chart:

$$\frac{\text{\# of meters of pipe (per diameter)}}{\text{lay length of pipe (m)}} = \text{\# of joints}$$

or

$$\frac{\text{\# of feet of pipe (per diameter)}}{\text{lay length of pipe (ft)}} = \text{\# of joints}$$

$$\frac{\text{\# of joints}}{\text{joints per container}} = \text{\# of containers}$$

### Curved Sewers

As a cost-saving alternative to manholes, gradual changes in direction for IPEX PVC sewer pipe may be achieved using one of the following:

- bending the pipe (IPEX Ring-Tite and Enviro-Tite only)
- deflecting the gasketed joint
- using IPEX PVC fittings

## A. Bending the Pipe Barrel

Smaller diameters of IPEX PVC Ring-Tite and Enviro-Tite Pipe up to 300 mm (12") diameter may be subjected to limited bending to follow the outline of a curved trench. **This practice should not be attempted with Ultra-Rib, Ultra-X2 and Centurion Pipe.**

The recommended procedure is as follows:

1. Make a concentric assembly in the usual way. Keep the pigot in straight alignment with the bell.
2. Place compacted backfill around the assembled joint to restrict its movement while the curvature is being made.
3. Place compacted backfill at the inside of the curve, at the mid-point of the pipe length, to form a fulcrum.
4. Using only manual effort, move the leading bell of the pipe length to be curved by no more than the offset distance shown in the following table.

Below is a table showing the minimum radius of curvature achieved by bending IPEX Ring-Tite and Enviro-Tite Pipe, and the resultant maximum offset for standard 4 m (13') lengths.

Pipe Size		Minimum Radius of Curvature		Maximum Offset, A	
mm	in	mm	in	mm	in
100	4	13	43	600	23
125	5	18	57	450	18
150	6	19	64	400	16
200	8	26	86	300	12
250	10	33	107	240	9
300	12	39	128	200	8

**Note:** Bending is not recommended for Ring-Tite and Enviro-Tite pipe sizes greater than 300 mm (12") or for any size of Ultra-Rib, Ultra-X2 and Centurion pipe.

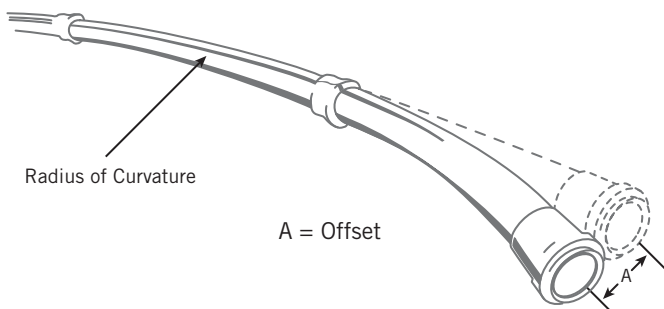

## B. Deflecting the Joint

The gasketed joints of IPEX PVC sewer pipe and fittings are flexible enough to permit deviation in the assembled joint for directional changes. Below is the recommended procedure for curving a pipeline using joint deflection:

1. Make a concentric assembly, but push the spigot into the bell only to a point about 13 mm (1/2") short of the reference line. This incomplete assembly permits more movement of the end of the pipe at the neck of the bell.
2. Shift the loose bell end of the assembled length by not more than indicated in the following table.
3. This procedure should not be used in conjunction with Method A (bending the pipe barrel).

Below is a table illustrating the maximum allowable angle of deviation at the bell of IPEX PVC sewer pipe, as well as the resultant maximum offset for a standard 4 meter (13') length.

Pipe Size		Angle at One Bell degrees (°)	Maximum Offset, B		Radius of Curvature	
mm	in		mm	in	m	ft
Ring-Tite and Enviro-Tite – 4m (13ft) lengths						
100 – 300	4 – 12	5	350	13.6	46	150
375 – 600	15 – 24	3	210	8.2	76	250
675 – 1500	27 – 60	1.5	105	4.1	150	490
Ultra-Rib – 4m (13ft) lengths						
200 – 600	8 – 24	5	350	13.6	46	150
Ultra-X2						
750 – 900	30 – 36	3	210	8	76	249
IPEX Centurion – 6.1m (20ft) lengths						
350 – 600	14 – 24	1.5	150	6.25	233	764
750 – 1500	30 – 60	1.0	100	4	349	1146

**Note:** If half lengths of pipe are used, the above offset values must be divided by two.

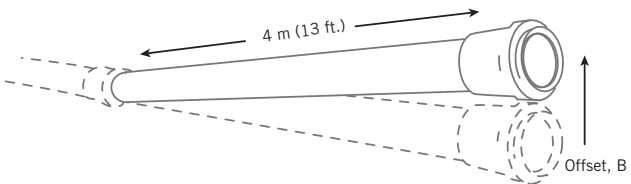

## C. Using PVC Fittings

IPEX offers standard elbows and short or long radius sweeps in 11-1/4°, 22-1/2°, 45° or 90°. PVC elbows can also be fabricated to any other angle configuration for all sizes of Ring-Tite, Enviro-Tite, Centurion, Ultra-Rib or Ultra-X2 pipe. These fittings are assembled in the same manner as the pipe.

### Field-Cut Assembly

Before assembly is being made using field-cut PVC sewer pipe, follow the instructions below:

- (a) **Ring-Tite, Enviro-Tite and Centurion Pipe** – The spigot end must be chamfered to a thickness of about 50% of the pipe wall at a bevel angle of 15°. Next, a reference line for insertion should be applied to minimize possibility of over-insertion. Dimension C in the table entitled, “Pipe Dimensions” (page 14), in this booklet may be used as a guide. Alternatively, the installer may determine the correct insertion line position from an uncut length of the same diameter pipe.

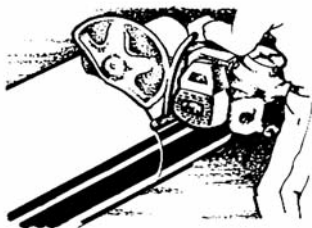

- (b) **Ultra-Rib Pipe** – A gasket must be field installed between the second and third ribs of the spigot end. An insertion line can be marked using the table below as a guide.

Pipe Size		Stop Mark (between ribs)
mm	in	
200	8	4 and 5
250	10	5 and 6
300	12	5 and 6
375	15	5 and 6
450	18	5 and 6
525	21	6 and 7

- (c) **Ultra-X2 Pipe** – A gasket must be field installed on the second valley of the spigot end. An insertion line can be marked using the table below as a guide.

Pipe Size		Stop Mark (from end of spigot)	
mm	in	mm	in
750	30	265	10.5
900	36	280	11



## Manhole Connections

Very often, connections of PVC sewer pipe to concrete manholes and other rigid structures require a watertight connection. Some options to obtain such a connection are described below.

### Ring-Tite and Enviro-Tite

1. **Gasketed Outlet** – Manhole suppliers normally offer a precast concrete base manhole with a gasketed outlet to accommodate smooth-walled Ring-Tite and Enviro-Tite PVC pipe. (IPEX Centurion's ODs must be specified prior to order.) The installer must simply specify the appropriate outside diameter of the pipe to ensure a properly sized gasket will be cast into the manhole. The Ring-Tite and Enviro-Tite pipe should be chamfered and lubricated before insertion.
2. **Grout Adapters** – These fittings are manufactured from a stub of Ring-Tite, Enviro-Tite and Centurion pipe that has been coated externally with a sand, epoxy, cement mortar mixture. A watertight connection can be made by placing the adapter into a manhole outlet followed by filling the annular space around the adapter with a non-shrink grout. The special coating is required because grout will not form a watertight bond with bare PVC pipe.

### Ultra-Rib/Ultra-X2

1. **Smooth-Walled Adapter** – IPEX offers a Bell x Spigot PVC adapter that will transform Ultra-Rib to smooth-walled Ring-Tite and Enviro-Tite outside diameter. Connection to the manhole can then be achieved exactly as described in Method 1 for Ring-Tite and Enviro-Tite pipe. The adapter will be factory chamfered.
2. **Grout Adapter** – The concept here is identical to the grout adapter used for Ring-Tite and Enviro-Tite pipe, except that the bell end of the grout adapter is made to accept an Ultra-Rib spigot. The procedure involves the application of a non-shrink grout to create a seal between the adapter and the concrete manhole wall. Some manhole manufacturers offer these type of adapters grouted into place in precast factory-made manholes for convenience to the pipeline installer.
3. **Straight Connection** – Although non-shrink grout will not bond to PVC, it will adhere to elastomeric gaskets. Thus, a watertight grout-sealed connection can be made to the Ultra-Rib providing there is an Ultra-Rib gasket on the pipe spigot. An even better seal can be obtained if two (2) gaskets are placed consecutively on the Ultra-Rib spigot.

## Manhole Installation Notes

- To minimize the effects of possible manhole settlement over time, shorter sections [typically 1 meter or (3')] of PVC sewer pipe should be used when entering and exiting the manhole.
- It is good practice to compact the foundation below the manhole to prevent excessive settlement.
- The area directly underneath the PVC pipe at the manhole should be supported by compacted soil or sand to assist in load bearing capacity.
- Manhole connections other than those listed above may be acceptable to the designer for varying water and soil tightness requirements.

## SERVICE CONNECTIONS

IPEX offers four methods of connecting service lines or tie-ins to PVC sewer pipe. PVC fittings are the preferred method for service connections for newly installed lines up to 375 mm (15"), while saddles and Inserta-Tees are advantageous for larger sizes and for tie-ins to existing sewer mainlines of all diameters. Solvent weld fittings are not compatible with fabricated gasketed fittings because the spigot is too short to engage the gasket in a fabricated fitting.

1. PVC Fittings – IPEX manufactures gasketed molded PVC fittings up to 375 mm (15"), and fabricated PVC fittings up to 1500 mm (60") in all configurations. Custom configurations can also be made to suit design needs. Joint assembly methods are the same as for pipe joints

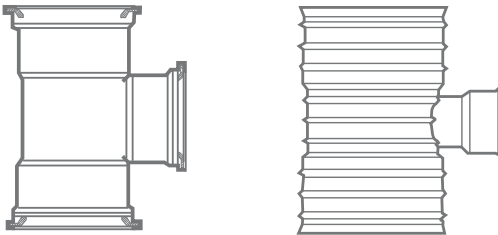

except the fittings may have different insertion depths. The insertion line on a factory-made pipe spigot should be disregarded when installing fittings on that spigot. A correct insertion distance may be determined by measuring the bell depth of the fitting with a measuring tape prior to assembly.

2. **Inserta-Tees** – These devices are available for use on Ring-Tite, Enviro-Tite, Ultra-Rib and Ultra-X2 PVC sewer pipe. Inserta-Tees can be installed on mainlines up to 1050 mm (42") diameter, with outlet sizes ranging from 100 mm (4") to 300 mm (12"). Follow the instructions below for proper installation:

Outlet Size		Hole Diameter	
mm	in	mm	in
100	4	114	4-1/2
150	6	165	6-1/2
200	8	222	8-3/4
250	10	276	10-7/8
300	12	327	12-7/8

(a) Core the appropriate sized hole with a hand-held drill with holesaw attachment. A tie-down coring machine is recommended for 250 mm (10") and 300 mm (12") Inserta Tee sizes. \*\*

(b) Insert the rubber sleeve into the hole with the gold vertical line on the rubber sleeve facing perpendicular to the direction of mainline flow. The upper lip should be positioned against the wall exterior, while the lower lip should be against the inner pipe wall.

(c) Apply Inserta-Tee solution to the rubber sleeve interior and the PVC hub exterior. **Do Not use an oil-based lubricant.**

(d) Place the PVC hub into the rubber sleeve while aligning the vertical red line on the PVC hub with the gold line on the rubber sleeve.

(e) Tap the PVC hub into the sleeve using a hammer and block of wood. The hub should only be inserted until the **horizontal** red line on the hub is even with the outer edge of the rubber sleeve.

(f) Place the stainless steel band around the top of the rubber sleeve and tighten. The lateral pipe can now be inserted into the PVC hub to complete the service connection.

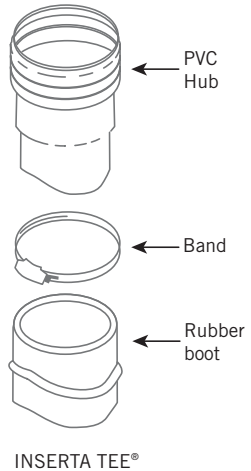

**Note:** Ensure that the Inserta-Tee used is designed for the type and size of pipe being used (i.e. for Ring-Tite, Enviro-Tite, Ultra-Rib or Ultra-X2).

\*\* The following precautions should be observed when hole-cutting through Ultra-Rib pipe:

- (i) use a variable speed drill
- (ii) to prevent binding, and possible injury, initially operate hole cutter in the reverse direction
- (iii) after establishing a groove, complete the hole in either the forward or reverse direction.

3. **Strap-On Gasketed PVC Saddles** – These devices are available as either tees or wyes. Mainline connections can be made to pipe as large as 1050 mm (42") with outlet sizes up to 150 mm (6") standardly available. **This method is for use on Ring-Tite and Enviro-Tite PVC pipe only.** The procedure below should be followed to ensure proper installation:

(a) Place saddle in position on pipe. Use the saddle as a template and marker guide for the hole cut-in. Remove the saddle from the pipe.

(b) Using the hole guide mark, cut a hole through the pipe wall outside the mark by the thickness of the saddle stem [more than 6 mm (1/4")]. Use a hand, keyhole or power jig saw to cut the hole. For wye saddles, cut or bevel the downstream side of the hole at a 45° angle to obtain a better fit for the saddle stem.

(c) Clean and dry both the underside of the saddle and the mating surface of the pipe.

(d) Position the saddle over the hole. Place the two (2) stainless steel hose clamps around the pipe and through the slots at each end of the saddle skirt. Check to see that the saddle stem is recessed into the hole for stability and that the straps are at right angles to the pipe surface.

(e) Tighten the straps alternately with a large screwdriver until the maximum torque has been reached by hand. The minimum applied torque should be 6.8 joules (5.0 ft/lbs).

(f) Place and tamp the select backfill around the pipe and saddle to provide firm and continuous support for both.

**Note:** If saddles are not properly positioned, the rubber gasket may not be touching the pipe wall which may result in a leak.

When performing any of the above service connection methods, every effort should be made to:

- (a) Ensure no foreign matter enters the main line through the connection outlet.
- (b) Keep the outlet plugged until the service lateral pipe is installed.
- (c) Keep the lateral service pipe capped at its terminating point until the house sewer line is later installed.

## Sewer Laterals

In general, service laterals should be taken off at an angle of no greater than 45 degrees from the horizontal. This will minimize the effects of side-soil friction imposing excessive downward loads on the service connection.

When connecting laterals, use a long sweep PVC bend wherever possible to facilitate changes in slope more gradually. Good compaction is **imperative** beneath the long sweep bends as well as below the branch of the service connection in order to maintain proper soil support. The PVC long sweep bends from IPEX are made to a radius of curvature of six (6) times the nominal diameter of the bend.

## Riser Problems Demand Special Attention

When vertical risers cannot be avoided, consult the design engineer as more special precautions may be required.

Service lines from the property to the street sewer demand special design considerations when the collection sewer is deeper than 4 m (13') regardless of the piping material used. Service risers from main sewers buried more than 4 m (13') should be taken off at an angle not less than 45° from the vertical. The service should then be moved to the vertical position by an appropriate elbow and vertical section of pipe. In sanitary sewer systems, drop laterals and drop manholes are the most common examples of areas requiring this special attention.

Drop laterals may create undue stresses on the buried pipe and fitting assembly. Horizontal portions of a lateral laid over disturbed uncompacted materials may experience a loss of bedding support if the foundation settles. This can lead to loss of grade and ultimately beam or shear failure in the pipe or fitting. As the soil adjacent to the pipe settles with the foundation, it attempts to drag the pipe with it, magnifying the load on the fittings.

It is critical to provide proper support beneath the mainline, service fitting, lateral, elevation fittings and their adjacent fill. Since this is usually difficult, the best approach is to turn the lateral down immediately when entering the trench and keep it against the trench wall thus eliminating any unsupported portion.

Keeping the drop portion (and the upper elbow) immediately adjacent to the trench wall can reduce drag down effects and

can control beam bending during backfill. Even then, the elbow at the bottom must be both strong enough and bedded on a sound foundation to react to the loads. As depths increase, settlement loads can ultimately fail the system or buckle the riser.

Designs employing sleeves or concrete encasement of the drop portion of the lateral are effective if the designer provides an adequate means of supporting the loads at the bottom.

Sleeving the lateral with a crushable sleeve such as corrugated polyethylene drainage tubing can also solve the problem. As the fill adjacent to the lateral settles, the sleeve folds up and moves down with it. This accordion-like effect displaces the load from the lateral. It should be noted that when this method is used, the annular space between the sleeve and the lateral should not be filled with backfill.

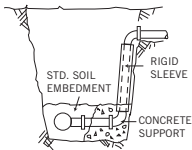
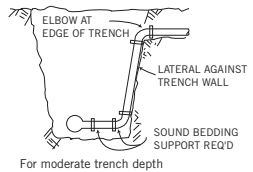
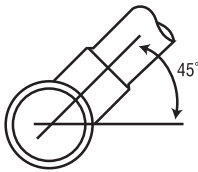
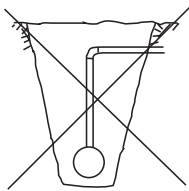

Rigid sleeve for any trench  
(concrete must support sleeve)

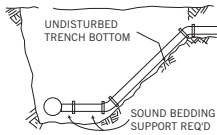

Sloping lateral trench - any depth  
(slope at 1:1 or flatter)

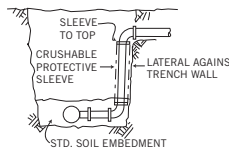

Crushable Sleeve - any depth  
(sleeve of near zero column strength)

## Backfilling and Tamping

Backfilling should follow pipe assembly as closely as possible. This protects pipe from falling rocks, eliminates possible lifting of the pipe off grade due to flooding, avoids shifting pipe out of line by cave-ins, and lessens the possibility that backfill material will freeze.

The two purposes for proper haunching and proper initial backfilling of PVC pipe are:

- (a) to provide the side soil support, which is necessary to enable the pipe and soil to work together to meet the designed load requirements within the allowable deflection limit.

(b) to provide protection for the pipe from impact damage due to large rocks, etc., contained in the final backfill.

After initial backfilling has been completed, the balance of the backfill can be done by machine.

### Tamping Equipment

The following are some forms of tamping equipment commonly used.

**Tamping Bars** – If manual tamping is to be done directly beside or above PVC pipe, tamping bars are preferred. Two types of tamping bars should be available for a good tamping job. First, a bar with a narrow head should be used. (See A or B below) These are used to tamp under the pipe. The second type of tamping bar should have a flat head. It is used to compact the soil along the sides of the pipe to the trench walls. (See C below) The flat tamper will not do the work of the tamping bar and vice-versa.

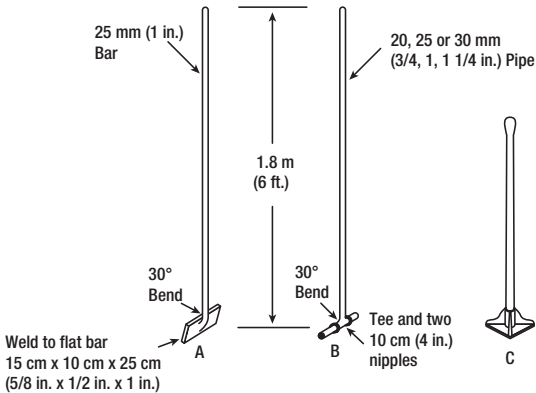

**Tampers** – These devices are well-suited for use in the Bedding, Haunch, Initial Backfill, or Final Backfill zones. A minimum cover of 300 mm (12") is recommended for jumping jacks to avoid excessive impacts, while flat plate tampers may be used with as little as 150 mm (6") of backfill over the pipe.

**Mechanical Compactors** – This category refers to such machines as hoe-pacs and vibratory rollers. They should only be used in the Final Backfill zone and must always have a minimum cover of 1 meter (3.3') above the pipe.

Flood or water tamping may be used as a method of compaction only in trenches that are excavated in soils from which water drains quickly. Care should be taken not to float the pipe. The introduction of water under pressure (i.e. water-jetting) should never be used to compact embedment soils of PVC pipe.

## TESTING OF SEWERS

### Joint Tightness Testing

To ensure the integrity of the assembled gasketed joints of a PVC sewer pipeline, the designer will often require testing after installation is complete. This testing is frequently a requirement for sanitary sewer lines and is a growing trend for storm sewer systems as well.

There are two options that may be specified by the designer to test joint tightness – air testing or water testing. Air testing is preferable where possible because of its accuracy, simplicity and minimal time consumption. Water testing tends to be more expensive than with air, but is advantageous in some situations.

#### 1. Air Testing

Here, the installer must plug both ends of a section of sewer to be tested before subjecting that section of pipe to low pressure air. The air must be maintained at a minimum pressure of 24.0 kPa (3.5 psi) for the specified time period for each diameter shown in the table below. Duration times vary with changes in pipe size and length of test sections. A maximum pressure drop of 3.5 kPa (0.5 psi) is permitted within the specified time duration. If a maximum pressure drop of 7.0 kPa (1.0 psi) is specified, the time values in the table should be doubled.

Should the pressure drop be greater than 3.5 kPa (0.5 psi) within the specified time duration, the installer must locate and repair any deficiencies at his own expense. Re-testing must be performed until a successful test is achieved. Sources of leaks may be dirt in an assembled gasketed joint, incorrectly tightened service saddles or improper plugging or capping of sewer lateral piping. If there is no leakage (i.e. zero pressure drop) after one hour of testing, the section should be passed and presumed free of defects.

If there is groundwater present at a level higher than the pipe invert during the air-test, the test pressure should be increased to a value of 24.0 kPa (3.5 psi) greater than the water head at the bottom of the pipe [to a maximum air test pressure of 34.0 kPa (5.0 psi)].



Pipe Size		Minimum Time min:sec	Length for Minimum Time		Time for Longer Meter Length sec	Time for Longer Feet Length sec
mm	in		m	ft		
100	4	1:53	182.0	600	0.62 L	0.19 F
125	5	2:31	137.0	450	1.10 L	0.34 F
150	6	2:50	121.3	400	1.40 L	0.43 F
200	8	3:47	90.8	300	2.49 L	0.76 F
250	10	4:43	72.8	240	3.89 L	1.19 F
300	12	5:40	60.7	200	5.61 L	1.71 F
375	15	7:05	48.5	160	8.76 L	2.67 F
450	18	8:30	40.5	133	12.62 L	3.85 F
525	21	9:55	34.7	114	17.17 L	5.24 F
600	24	11:20	30.2	100	22.43 L	6.84 F
675	27	12:45	26.8	88	28.38 L	8.65 F
750	30	14:10	24.4	80	35.04 L	10.68 F
900	36	17:00	20.1	66	50.47 L	15.38 F
1050	42	19:54	17.4	57	68.71 L	20.94 F
1200	48	22:47	15.2	50	89.74 L	27.35 F
1350	54	25:31	13.4	44	113.58 L	34.62 F
1500	60	28:20	12.2	40	140.22 L	42.74 F

where L = length of test section in meters

F = length of test section in feet

**example** – If there is 0.5 meters (1.65 ft.) of water above the invert of a buried PVC sewer line, what must the air-test pressure be?

**solution** – The static head of the groundwater at the pipe invert will be:

$$0.5 \text{ m} \times (9.73 \text{ kPa} / \text{m}) = 4.87 \text{ kPa}$$

therefore, the total air-test pressure should be:

$$4.87 \text{ kPa} + 24.0 \text{ kPa} = 28.87 \text{ kPa}$$

or

$$1.64 \text{ ft.} \times (.43 \text{ psi} / \text{ft.}) = .71 \text{ psi}$$

therefore, the total air-test pressure should be:

$$.71 \text{ psi} + 3.5 \text{ psi} = 4.21 \text{ psi}$$

Since this value is less than 34.0 kPa (5.0 psi), the installer may proceed with the air test using this start pressure.

Knowing the density of water to be 1000 kg/m<sup>3</sup> (62.4 lb/ft<sup>3</sup>), the maximum head of groundwater permitted above the invert of a PVC sewer pipe for an air test is 1 meter (3.3').

## 2. Water Testing

**Infiltration** – The allowable infiltration for any pipe section should be measured by a weir or current meter placed in an appropriate manhole. This is an acceptable method of leakage testing only when the ground-water level is above the top of the pipe throughout the section of line being tested. It is especially useful when the water table is well above the top of the pipe. Usually the designer will give explicit instructions for conducting the test.

**Exfiltration** – This test is suitable for very dry areas, or where the water table is suitably low that test pressures can easily exceed the static head of the water table. Test pressures should be a minimum of 5.9 kPa (0.9 psi) above the water table head. The test section of pipe shall be filled with water and the leakage rate measured.

For sizes 100 mm - 375 mm (4" - 15"), the allowable leakage rate shall be 4.63 liters per mm of pipe diameter per kilometer per 24 hours (50 USgal./inch/mile/day). For sizes 450 mm (18") and larger, the allowable rate for testing shall be 0.93L/mm/km/day (10 USgal./inch/mile/day). Should the allowable leakage rate be exceeded for either an infiltration or exfiltration test, the installer must locate and repair any deficiencies at his own expense until a successful test is conducted. Tests are typically conducted from manhole to manhole.

### Deflection Testing

Deflection is the way a flexible pipe reacts to vertical soil loads when buried in a trench. It illustrates how the pipe and surrounding soil work together to easily withstand common, and even extreme soil loads.

The maximum deflection of plastic pipe or fittings can be accurately predicted by the designer by knowing the pipe stiffness, soil stiffness and the height of cover. For the majority of underground PVC sewer pipe applications, with proper compaction, the deflection will be well within the recommended maximum allowable of 7.5%. However, if the designer has reason to believe that excessive deflection may be present, a deflection test may be necessary.

There are two commonly used methods of performing deflection tests on PVC sewer pipe:

1. Go/No-Go Device
2. Physical Measurement

## 1. Go/No-Go Device

The most popular method of the two is the rigid Go/No-Go mandrel. This gage can accurately determine whether the deflection is within specified limits. The test involves the pulling of a mandrel through an installed sewer line. The mandrel will simply get stuck if the actual deflection is beyond the specified limit (normally 7.5%). The mandrel must be designed to have dimensions which exactly match the clearance inside the pipe, at the deflection limit.

Below is a detailed drawing of a suggested mandrel design for 7.5% deflection, along with tables of appropriate dimensions for Ring-Tite, Enviro-Tite and Ultra-Rib Pipes.

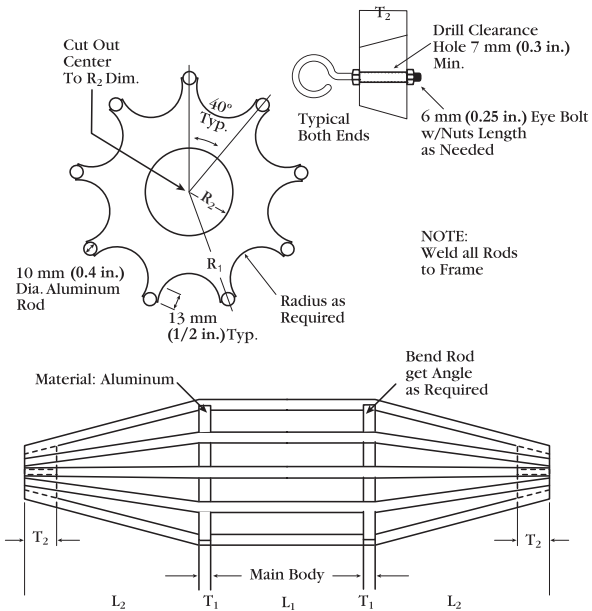

Pipe Size		Base I.D.		L1, L2		R2		R1	
mm	in	mm	in	mm	in	mm	in	mm	in

#### Ring-Tite and Enviro-Tite - Mandrel Dimensions

200	8	194.7	7.67	150	6	35	1.4	90.0	3.54
250	10	242.9	9.56	200	8	40	1.6	112.3	4.42
300	12	288.6	11.36	200	8	45	1.8	133.5	5.26
375	15	353.0	13.90	230	10	50	2.0	163.3	6.43
450	18	431.2	16.98	300	12	55	2.2	199.4	7.85
525	21	508.1	20.00	300	12	60	2.4	235.0	9.25
600	24	571.0	22.48	350	14	65	2.6	264.1	10.40
675	27	643.3	25.33	350	14	70	2.8	297.5	11.71

#### Ultra-Rib - Mandrel Dimensions

200	8	196.1	7.7	150	6	35	1.4	91.2	3.6
250	10	245.2	9.7	200	8	40	1.6	114.0	4.5
300	12	291.8	11.5	200	8	45	1.8	135.7	5.3
375	15	357.3	14.1	230	10	50	2.0	166.1	6.5
450	18	438.7	17.3	300	12	55	2.2	204.0	8.0
525	21	515.8	20.3	300	12	60	2.4	239.8	9.4
600	24	584.2	23.0	350	14	65	2.6	271.7	10.7

#### Notes:

- T1 = 10 mm (0.4") and T2 = 25 mm (1") for all sizes of mandrels
- For pipes larger than 675 mm (27"), physical measurement is recommended.
- Two times dimension R1 is critical passing dimension for deflection mandrels.

## 2. Physical Measurement

To begin this process, measure the vertical inside diameter at a particular point in a PVC sewer pipe before it is installed (D1). Next, measure the inside diameter at that same point after the pipe has been installed and completely backfilled (D2). Now, the deflection at that point can be computed as follows:

$$\text{Deflection} = \frac{D1 - D2}{D1} \times 100\%$$

For accurate results, a micrometer should be used.

## Videos

The use of video cameras to inspect the interior of newly installed sewer pipe is very common today. The idea of videotaping the inside of sewer lines was first conceived to fulfill the need to evaluate the decaying condition of older sewers made from traditional pipeline materials such as clay, brick or concrete. The only practical benefit of videos with regard to newly installed PVC sewer pipe is in detecting glaring installation deficiencies such as leaking joints or excessive deflections. Although videos are able to pinpoint the location of a deficiency, they are unable to quantify the magnitude of a problem or whether the deficiency is within allowable limits.

## SPECIAL APPLICATIONS

### Installing Pipe Through Casings

When the direction of pipe laying intercepts a heavily travelled, protected or landscaped area, it may be advantageous to install the pipe through a protective casing. A casing may be required for one of the following reasons:

1. To make the pipeline accessible without excavating the surface.
2. For installation savings compared to jacking PVC sewer pipe directly through the unexcavated area.
3. To absorb the effects of extreme impact load situations (i.e. railway loading with shallow burial).

There are four major precautions to observe in the design and installation of PVC pipe in casings. To ensure proper installation always:

1. Select the appropriate casing size
2. Install spacers or skids on the PVC pipe
3. Minimize the friction force during the pull to avoid over-insertion
4. Install a water-permeable seal at the casing ends

## Casing Size

The casing size should be large enough to readily accommodate the maximum outside diameter of the pipe bells and the projections of the supporting skids. The bell OD's for Ring-Tite, Enviro-Tite, Ultra-Rib and Ultra-X2 are presented in the Pipe Dimensions section found on pages 14 to 17.

On the following page is a summary of the recommended casing sizes for each diameter of PVC sewer pipe.

Pipe Size		Minimum Casing Size	
mm	po	mm	po
100	4	250	10
125	5	300	12
150	6	300	12
200	8	400	16
250	10	450	18
300	12	500	20
375	15	660	26
450	18	750	30
525	21	810	32
600	24	865	34
675	27	965	38
750	30	1220	48
900	36	1270	50
1050	42	1400	56
1200	48	1550	62
1350	54	1825	72
1500	60	1981	78

## Casing Material Choices

Various options are available for the casing pipe including steel, corrugated metal, concrete or large diameter PVC pipe. Factors such as soil conditions, corrosion resistance, and required pull or push forces should all be considered. If the casing can be installed in an open-cut excavation, PVC pipe would be an ideal choice. IPEX can offer a suitable PVC casing pipe up to 1200 mm (48") in diameter. Minimum cover for PVC casings with H-20 traffic loads should be 300 mm (12").

## Skids

The pipe should not rest on the bells after installation in the casing. Runners or skids should be attached to the pipe with steel straps for a sufficient distance along the barrel to prevent any portion of the pipe from touching the casing. Pipe sizes 300 mm (12") and under should have 4 skids arranged at 90° intervals around the pipe. Pipes over 300 mm (12") should have 6 skids positioned 60° apart. To help avoid over-belling as the pipe is being pushed or pulled through the casing, place one set of runners with their ends even with the insertion lines on the pipe spigot.

If this method is used, ensure that the wood has not been treated with creosote which could harm PVC over its lifetime. To check the compatibility of any other wood preservatives with PVC, consult the IPEX Chemical Resistance Guide or call your local IPEX representative.

## Mechanical Casing Spacers

Molded plastic spacers can be used on Ring-Tite, Enviro-Tite and Ultra-Rib and Ultra-X2 pipes. These molded pipe spacers are available to provide insulating protection between the carrier pipe and the casing. These spacers are manufactured from polyethylene,

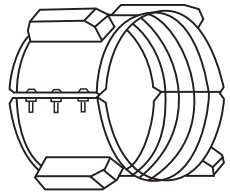

stainless steel or carbon steel and come complete with runners to provide clearance for the bell and spigot assemblies. The casing spacer manufacturer should be contacted for direct information on the location and number of casing spacers required.

## Pulling Pipe Through Casings

A common method used for pulling pipe through a casing requires the feeding of a cable through the casing and the first length of pipe, then attaching it to a wooden cross-piece over the face of the bell-end. The length of pipe is then pulled back through the casing and repeated for the next lengths.

Each length must be inserted into the bell-end of the previous length as is done in regular assembly. The pull should be slow and steady while avoiding any jerking movements. Place a protective wrap around the spigot end of the first length to minimize any possible abrasion against the casing.

Non-petroleum based lubricants applied to the casing interior or skid exteriors will make the sliding easier.

## Sealing the Casing

IPEX does not recommend the use of cement grouting between the pipe wall and the casing. The grout will transfer the external load from the casing directly onto the pipe. After the pipeline has been tested and accepted, the space between the pipe and casing should be sealed with a permeable grouting material at the entry and exit points only. The chosen material should be selected so that backfill cannot enter the casing, while water is permitted to escape. If the installer is obliged to use a grout, the grout pressure must not exceed 80 kPa

(12 psi) at 23°C (73°F) or lower. If warmer temperatures will be encountered the grouting pressure must be decreased. Contact IPEX for further information.

If pressure grouting is to be used, the following precautions should be observed:

1. Support the pipe with either skids or casing spacers.
2. Fill the pipe section to be grouted with water.
3. Use a lightweight grout to minimize buoyancy forces.
4. Gravity flow the grout into the annular space.
5. Do not exceed maximum grouting pressures.

### Maximum Recommended Grouting Pressure

DR	Maximum Grouting Pressure	
	(kPa)	(psi)
51	25	not recommended
41 / Ultra-X2	50	not recommended
35 / Ultra-Rib	82	12
28	164	24

These maximum pressures are based on the temperature in the wall of the pipe not exceeding 23°C (73°F). Maximum grouting pressures must be reduced with increased wall temperatures.



### Percent (%) Deflection of Ring-Tite, Enviro-Tite DR35,

ASTM Embedment Material Classification		Density (Proctor) AASHTO T-99	E' psi (kPa)	0.3	
				meters	1
Manufactured Granular Angular	Class I	90%	3 000 (20 700)	0.7	
Clean Sand and Gravel	Class II	90%	2 000 (13 800)	1.1	
		80%	1 000 (7 000)	2.0	
Sand and Gravel with Fines	Class III	90%	1 000 (7 000)	2.0	
		85%	500 (3 500)	n/r	
Silt and Clay	Class IV	85%	400 (2 760)	n/r	

### Percent (%) Deflection of IPEX Centurion

ASTM Embedment Material Classification		Density (Proctor) AASHTO T-99	E' psi (kPa)	DR	0.3	
					meters	1
Manufactured Granular Angular	Class I	90%	3 000 (20 700)	51		
				41		
Clean Sand and Gravel	Class II	90%	2 000 (13 800)	51		
				41		
		80%	1 000 (7 000)	51		
				41		
Sand and Gravel with Fines	Class III	90%	1 000 (7 000)	51		
				41		
		85%	500 (3 500)	51		
				41		
Silt and Clay	Class IV	85%	400 (2 760)	51		
				41		

1. Deflection values shown include effect of H-20 live load and dead load.
2. External loading based upon a prism load of soil weight of 1900 kg/m<sup>3</sup> (120 lbs. per cubic foot)
3. Bedding classifications correspond to ASTM D2321.

## Ultra-Rib and Ultra-X2

Depth of Cover												
	0.6	1	2	3	4	5	6	7	8	9	10	15
	<b>2</b>	<b>3.3</b>	<b>6.6</b>	<b>9.8</b>	<b>13.1</b>	<b>16.4</b>	<b>19.7</b>	<b>23.0</b>	<b>26.3</b>	<b>29.5</b>	<b>32.8</b>	<b>49.2</b>
0.5	0.3	0.4	0.4	0.4	0.6	0.7	0.9	1.0	1.2	1.3	1.4	2.2
0.7	0.5	0.5	0.6	0.8	1.1	1.3	1.5	1.7	1.9	2.1	2.1	3.2
1.4	1.0	1.0	1.2	1.6	2.0	2.4	2.8	3.2	3.6	4.0	4.0	6.0
1.4	1.0	1.0	1.2	1.6	2.0	2.4	2.8	3.2	3.6	4.0	4.0	6.0
2.5	1.7	1.8	2.2	2.9	3.7	4.4	5.1	5.9	6.6	7.3	7.3	<b>11.0</b>
3.0	2.1	2.2	2.6	3.5	4.4	5.3	6.1	7.0	7.9	8.8	8.8	<b>13.1</b>

Depth of Cover												
	0.6	1	2	3	4	5	6	7	8	9	10	15
	<b>2</b>	<b>3.3</b>	<b>6.6</b>	<b>9.8</b>	<b>13.1</b>	<b>16.4</b>	<b>19.7</b>	<b>23.0</b>	<b>26.3</b>	<b>29.5</b>	<b>32.8</b>	<b>49.2</b>
0.5	0.4	0.4	0.4	0.4	0.6	0.7	0.9	1.0	1.2	1.3	1.5	2.2
0.5	0.3	0.4	0.4	0.4	0.6	0.7	0.9	1.0	1.2	1.3	1.5	2.2
0.7	0.5	0.5	0.7	0.9	1.1	1.3	1.5	1.8	2.0	2.0	2.2	3.3
0.7	0.5	0.5	0.6	0.9	1.1	1.3	1.5	1.7	1.9	2.2	2.2	3.2
1.5	1.0	1.1	1.3	1.7	2.2	2.6	3.0	3.5	3.9	4.3	4.3	6.5
1.4	1.0	1.0	1.3	1.7	2.1	2.5	2.9	3.4	3.8	4.2	4.2	6.3
1.5	1.0	1.1	1.3	1.7	2.2	2.6	3.0	3.5	3.9	4.3	4.3	6.5
1.4	1.0	1.0	1.3	1.7	2.1	2.5	2.9	3.4	3.8	4.2	4.2	6.3
n/r	2.0	2.1	2.5	3.3	4.2	5.0	5.9	6.7	7.5	7.5	<b>8.4</b>	<b>12.6</b>
n/r	1.9	2.0	2.4	3.1	3.9	4.7	5.5	6.3	7.1	7.1	<b>7.9</b>	<b>11.8</b>
n/r	2.4	2.6	3.1	4.1	5.2	6.2	7.2	<b>8.3</b>	<b>9.3</b>	<b>10.3</b>	<b>10.3</b>	<b>15.5</b>
n/r	2.3	2.4	2.9	3.8	4.8	5.7	6.7	<b>7.7</b>	<b>8.6</b>	<b>9.6</b>	<b>9.6</b>	<b>14.4</b>

- The deflection lag factor is 1.0 for a prism load.
- Recommended maximum deflection of 7.5% provides a 4 to 1 factor of safety.
- Deflection values for DR28 will be slightly less than those above.

## Deep Burial

The successful performance of PVC pipe is principally governed by limiting its deflection. The prism load method is typically used to evaluate the load on PVC pipe. This equals the maximum actual load the pipe will have to withstand.

The tabular values presented on the following two pages are long-term deflections after final consolidation of the backfill in the pipe zone. IPEX recommends that the maximum long-term deflection for PVC pipe should be set at 7.5%. Since the critical deflection value for PVC is 30%, the designer is provided with a 4 to 1 safety factor (30/7.5) against any possible leakage or structural problems.

The first table of deflections is presented for the Ring-Tite, Enviro-Tite, Ultra-Rib and Ultra-X2 products. The second table is for deflection of IPEX Centurion DR41 and DR51 Pressure Pipe. This pipe is becoming very popular for gravity sewers in 600 mm (24") and larger sizes due to its larger inside diameter, even tighter joints and cost savings versus Ring-Tite and Enviro-Tite DR35.

## Shallow Burial

When subjected to live traffic loading (H-20), the minimum cover for DR28, DR35, Ultra-Rib and Ultra-X2 pipe is 300 mm (12"). The installation must be done to yield a minimum soil stiffness ( $E'$ ) of 7 000 kPa (1 000 psi) in the haunch zone around the pipe.

For DR41 and DR51 pipe, the minimum cover for H-20 loading shall be 600 mm (24"). The same minimum  $E'$  of 7 000 kPa (1 000 psi) should be obtained at this depth.

## Tie-in Connections

For the installer, one of the more favorable aspects of PVC sewer pipe, is the ease and simplicity of tie-ins.

Specific instructions are described below.

### Ring-Tite, Enviro-Tite and Centurion

1. To cut saw an Enviro-Tite Pipe, a miter box, regular hand or abrasive wheel saw should be used. The cut should be square to ensure proper assembly.

**Note:** If an abrasive wheel saw is used to cut PVC pipe, protective goggles must be worn by the operator. When cutting in a confined space, a dust mask should be worn over the nose and mouth.

- Next, the spigot end should be chamfered at an angle of 15° to a wall thickness of 50% of the original at the edge. Beveling can be done using a sander, hand-file, router or side of an abrasive wheel saw blade. Ensure that all sharp edges are removed to prevent damage to the gasket during assembly.
- An insertion line should then be marked circumferentially on the pipe spigot to act as a guide for correct insertion depth. Dimension, C, from the table entitled, "Pipe Dimensions" found on pages 14 and 17 will indicate the insertion line position if assembly is to be made into a pipe bell or the bell of an IPEX fabricated fitting. If assembly is to be made to an injection molded PVC fitting, the installer should physically measure the bell depth before applying an appropriate insertion line on the cut pipe.

### Ultra-Rib & Ultra-X2

- The same tools may be used to cut the Ultra-Rib and Ultra-X2 as were suggested for Ring-Tite and Enviro-Tite pipe. The center groove between ribs should be used as a guide for proper square-end cuts.
- To create a spigot for Ultra-Rib: A gasket is field applied to the plain end between the second and third ribs.

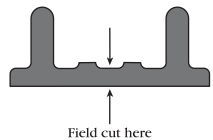

Ultra-X2: A gasket is field applied to the second valley of the spigot end.

- Insertion into another length of Ultra-Rib and Ultra-X2 or the bell-end of a fitting is done using the table presented in the section entitled, "Field Cut Assembly".

### Repairs

Repairs can be made for Ring-Tite, Enviro-Tite, Centurion, Ultra-Rib or Ultra-X2 pipe in a similar fashion. One would simply insert a replacement section of pipe into the damaged area, and join it to the existing pipe by means of two repair couplings. If one of the ends of the existing pipe is a bell-end, only one repair coupling is required.

Should it be necessary to replace a section of pipe, IPEX provides a repair coupling to simplify and speed up the repair operation. The replacement section can consist of a length of pipe with two spigot ends and two double bell repair couplings or a length of pipe with an integral bell and one spigot end and one double bell repair coupling.

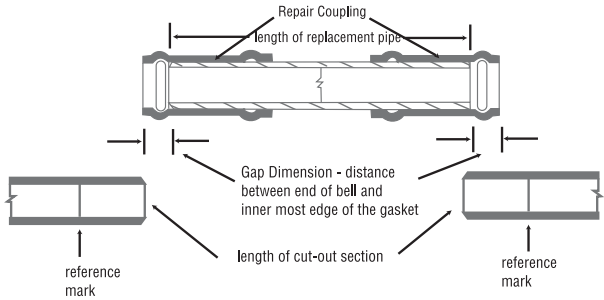

When cutting out the section to be repaired, ensure that no damaged areas remain (i.e. no hairline fractures).

A minimum pipe length of 0.6 m (2") will give sufficient work space for a repair.

1. Determine the length of the replacement section as shown above. Cut the pipe to the proper length.
2. Bevel the ends of the pipeline and the repair section. Locate the reference marks on all ends.
3. Mount the couplings as shown above or on the pipeline ends instead of the replacement section.
4. Insert the replacement section into the pipeline and slide the couplings into position as shown below. The couplings should be centered over the gap and midway between the reference marks.

When using a section with an integral bell, additional pipe length may need to be exposed. This will enable the pipeline to be deflected to allow proper alignment of the replacement joint. When determining the length of the replacement section, take care to allow for the gap dimension on one end only. Complete the integral bell joint first then slide the double bell coupling into place.

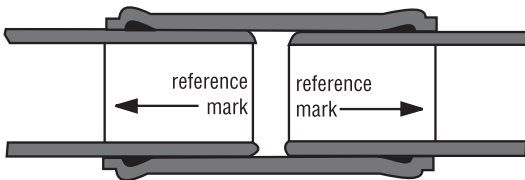

## Solvent-Weld Pipe & Fittings

Many times, pipe other than gasketed joint PVC is used for underground drainage or sewage. Some of the IPEX products that would fall into this category include PVC Drainline, System 15 DWV, Series PVC, PVC or CPVC Schedule 40 and 80, BlazeMaster CPVC or ABS-DWV. Here are some notes regarding the use of these products underground:

1. Assemble the pipe using the appropriate cement and primer for the pipe material and application. Solvent-welding procedures should conform to the recommendations below.
2. Trench zone recommendations for solvent-welded pipes are exactly the same as those for Ring-Tite, Enviro-Tite, Ultra-Rib and Ultra-X2 pipe, as described in this booklet.
3. The joints of a solvent welded pipe system are rigid, and thus have no capability to offer flexibility or deviation at the joint. However, the pipe barrel may be bent within specified limits. Contact IPEX for details.

## SOLVENT CEMENTING

Many solvent cementing techniques have been published, covering step-by-step procedures on how to make a solvent-cemented joint. What follows is a review of these basic principles along with the techniques needed to suit particular applications, temperature conditions and variations in sizes and fits of pipe and fittings.

### Principles of Solvent Cementing

To make consistently tight joints, the following points should be clearly understood:

1. The joining surfaces must be softened and made semi-fluid.
2. Sufficient cement must be applied to fill the gap between pipe and fittings.
3. Assembly of pipe and fittings must be made while the surfaces are still wet and fluid.
4. Joint strength develops as the cement dries. In the tight part of the joint, surfaces tend to fuse together; in the loose part, the cement bonds to both surfaces.

Penetration and softening can be achieved by the cement itself, by a suitable primer, or by the use of both primer and cement. A suitable primer will usually penetrate and soften the surfaces more

quickly than cement alone. In addition, the use of a primer provides a safety factor for the installer. For example, in cold weather, more time and additional applications of the solvent are required.

Apply generous amounts of cement to fill the loose part of the joint. In addition to filling the gap, adequate cement layers will penetrate the surfaces and remain wet until the joint is assembled. To prove this, apply two separate layers of cement on the top surface of a piece of pipe. First, apply a heavy layer of cement; then beside it, a thin, brushed-out layer. Test the layers every 15 seconds by gently tapping with your finger. You will note that the thin layer becomes tacky and then dries quickly (probably 15 seconds). The heavy layer will remain wet much longer. Check for penetration a few minutes after applying these layers by scraping them with a knife. The thin layer will have little or no penetration, while the heavy layer will have more penetration.

If the cement coatings on the pipe and fittings are wet and fluid when assembly takes place, they tend to flow together, becoming one cement layer. Also, if the cement is set, the surfaces beneath the pipe and fittings will still be soft. These softened surfaces in the tight part of the joint will fuse together.

As the solvent dissipates, the cement layer and the softened surfaces will harden with a corresponding increase in joint strength. A good joint will withstand the required working pressure long before the joint is fully dry and final strength is obtained. In the tight (fused) part of the joint, strength will develop quicker than in the looser (bonded) part of the joint.

## Solvent Cementing Instructions

### Handling

Solvent cements should be used as received in original containers. Adding thinners to change viscosity is not recommended. If the cement is jelly-like and not free-flowing, it should not be used. Containers should be kept tightly covered when not in use to stop the evaporation of the solvent.

### Storage Conditions

Solvent cements should be stored at temperatures between 4°C and 43°C (40°F and 110°F) away from heat or open flame. Cements should be used before the expiry date stamped on the container. If new cement is subjected to freezing temperatures, it may become extremely thick. If the cement is not jelly-like, it can

be placed in a warm area where it will soon return to its original, usable condition. However, if hardening is due to actual solvent loss (when a container is left open too long during use or not sealed properly after use), the cement will not return to its original condition. Cement in this condition has lost its formulation and should be discarded in an environmentally safe manner.

### Safety Precautions

Solvent cements are extremely flammable and should not be used or stored near heat or open flame. In confined or partially enclosed areas, a ventilating device should be used to remove vapors and minimize inhalation. Containers should be kept tightly closed when not in use, and covered as much as possible when in use. Avoid frequent contact with the skin. In case of eye contact, flush repeatedly with water. Keep out of the reach of children.

### Cold Weather

Although normal installation temperatures are between 4°C and 43°C (40°F and 110°F), high strength joints have been made at temperatures as low as -26°C (-15°F) with good cements. To do this, the installer must ensure he has adequately softened the joining surfaces as outlined in the following steps of this manual. In addition, cement must be kept warm to prevent excessive thickening and gelation in cold weather.

### Preparation

1. Use a handsaw and miter box or mechanical saw to cut squarely. A diagonal cut reduces the bonding area in the most effective part of the joint.
2. Plastic tube cutters may also be used for cutting plastic pipe. However, some cutters produce a raised bead at the end of the pipe. Remove any raised beads with a file or reamer, as it will wipe the cement away when pipe is inserted into the fitting.
3. Remove all burrs from both the inside and outside of the pipe with a knife, file or reamer. Burrs can scrape channels into pre-softened surfaces or create hang-ups inside surface walls.
4. Remove dirt, grease and moisture; a thorough wipe with a clean dry cloth is usually sufficient. Moisture will retard cure, and dirt or grease can prevent adhesion. Solvent cementing should not be attempted in the rain.



5. Check pipe and fittings for fit (dry) before cementing.

For proper interference fit, the pipe must go easily into the fittings one-third to three-quarters of the way. Too tight a fit is not desirable. You must be able to fully bottom the pipe in the socket during assembly with cement.

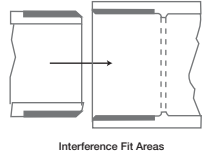

If the pipe and fittings are not out of round, a satisfactory joint can be made if there is a "net" fit, i.e. the pipe bottoms in the fitting socket with no interference, but without excess movement.

6. Use the right applicator for the size of pipe or fittings being joined:
- For pipe sizes 7.5 mm through 25 mm (3/8" through 1"), use the 20 mm (3/4") dauber
  - For sizes 20 mm through 50 mm (3/4" through 2"), use the 25 mm (1") brush
  - For sizes 20 mm through 75 mm (3/4" through 3"), use the 38 mm (1-1/2") dauber
  - For sizes 75 mm through 600 mm (3" through 24"), use a roller or paintbrush with a width equal to about one half the pipe diameter being cemented.

It is important that the correct size applicator be used to ensure that sufficient layers of cement are applied.

7. The purpose of the primer is to penetrate and soften the pipe and fitting surfaces so that they can be fused. The use of the primer and the checking of its softening effect provides assurance that the surfaces are prepared for fusion in a wide variety of conditions. Also, always check the penetration or softening on a piece of scrap pipe before you start the installation and if the weather changes during the installation process. Use a knife or sharp scraper and draw the edge over the coated surface. Proper penetration has been made if you can scrape away a few thousandths of an inch of the primed surface. As weather conditions affect priming and cementing action, repeated applications to one or both surfaces may be necessary. In cold weather, more time is required for proper penetration.
8. Using the correct applicator (as outlined in step 6), apply primer freely to the fitting socket, keeping the surface and applicator wet until the surface has been softened. This will usually take 5 - 15 seconds. More time is needed for hard

surfaces and cold weather conditions. Redip the applicator in primer as required. When the surface is primed, remove any puddles of primer from the socket of the fitting.

9. Apply the primer to the spigot end equal to the depth of the fitting socket. Use the same method of application used on the fitting socket.
10. A second application of the primer in the socket is recommended.
11. Immediately after reapplying the primer, and while the surfaces are still wet, apply the appropriate cement. The correct cement for the job can be quickly determined by reading the container labels. Be sure that the cement is in a fluid condition. If it is thicker than normal or appears gel-like, it should not be used.
12. Stir the cement and apply it, using the correct applicator (outlined in step 6). Apply a thick, even layer of cement on the spigot, equal to the depth of the socket. Flow the cement on with the applicator. **DO NOT** brush it out to a thin layer which will dry in a few seconds.
13. Apply a medium layer of cement to the fitting socket; avoid puddling the cement in the socket. On bell-ended pipe, do not coat beyond the socket depth or allow cement to run down in the pipe beyond the bell.
14. Apply a second thick, even layer of cement on the spigot. There must be more than sufficient cement to fill any gap in the joint. Large-sized pipe and fittings may require two or more workers to apply the primer and cement, and assemble the pipe and fitting.

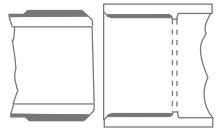

Cement Coatings of Sufficient Thickness

15. Attach the pipe to the fitting without delay. Cement must be wet. Use sufficient force to ensure that the spigot bottoms into the fitting socket. If possible, twist the spigot one-eighth to one-quarter turn as it is inserted.
16. Hold the pipe and fitting together for a short time (5 - 30 seconds) to eliminate pushout. Larger sizes with tight fits may require more time. Since the fitting sockets are made with a taper, the pipe may move back out of the fittings just after assembly.
17. A joint will have a ring or bead of cement completely around the juncture of the pipe and fitting after assembly. If voids in this ring are present, insufficient cement was applied and the joint may be defective.

18. Using a cloth, remove all excess cement from the pipe and fitting, including the ring or bead, as it will needlessly soften the pipe and the fitting, and does not add to joint strength.

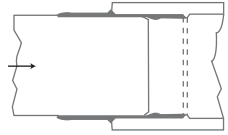

Assembly of Surfaces While They are Wet and Soft

19. Handle newly assembled joints carefully until the initial set has taken place. Recommended setting time allowed before handling or moving is related to temperature and found on the next page.

20. Joint strength development is very rapid within the first 48 hours. Short cure periods are satisfactory for high ambient temperatures with low humidity, small pipe sizes and interference-type fittings. Longer cure periods are necessary for low temperatures, large pipe sizes, loose fits and relatively high humidity.

**Note:** For solvent cementing 200 mm (8") and larger pipe and fittings, the following is recommended:

- a. Two operators are needed, simultaneously applying primer and cement to the pipe and fittings.
- b. A heavy-bodied, medium setting cement such as IPS Weld-On 711 or an extra-heavy, high-strength cement such as IPS Weld-On 719 are recommended. They provide thicker layers and have higher gap-filling properties. They also allow slightly more open time before assembly.
- c. A mechanical device may be needed to pull the joint together. This may be as simple as a 2 x 4 and a bar, or another method is to use two "come-alongs" or lever pullers. Sufficient chain with a choker strap is laid out on either side of the joint. The "come-alongs" are then laid out on either side of the joint, adjusted to the correct length which is equivalent to the insertion depth. The primer and cement are applied; the "come-alongs" are immediately hooked up, and the joint pulled together.

Temperature Range		Pipe Size					
		100-200	4-8	250-375	10-15	> 375	>15
C	F	mm	in	mm	in	mm	in
15 to 38	60 to 100	90 minutes		2 days		3 days	
4 to 15	40 to 60	4 hours		4 days		6 days	
-18 to +4	0 to 40	3 hours		8 days		8 days	

## Initial Set Time Schedule

### Initial Set Schedule for PVC Solvent Cements\*

Temperature Range		Pipe Size					
		100-200	4-8	250-375	10-15	> 375	>15
°C	°F	mm	in	mm	in	mm	in
15 to 38	60 to 100	30 minutes		2 hours		4 hours	
4 to 15	40 to 60	2 hours		8 hours		16 hours	
-18 to +4	0 to 40	12 hours		24 hours		48 hours	

**Note:** Initial set schedule is the necessary time to allow before the joint can be carefully handled.

\* These figures are estimates based on our laboratory tests. Due to the many variables in the field, these figures should be used as a general guide only.

After the initial set time, the joints will withstand the stresses of a normal installation. (A misaligned installation will cause excessive stresses in the joint.) For long runs of pipe, care should be taken not to disturb joints for 1/2 to 1-1/2 hours before handling or burying.

## Joint Cure Schedule

The following cure schedules may be used to determine the necessary time required after assembly before testing the system or before line pressure can be applied.

### Joint-Cure Schedule for PVC Solvent Cements\*\* (for Relative Humidity 60% or Less)

Temperature Range		Pipe Size					
		100-200	4-8	250-375	10-15	> 375	>15
°C	°F	mm	po	mm	po	mm	po
15 to 38	60 to 100	90 minutes		2 days		3 days	
4 to 15	40 to 60	4 hours		4 days		6 days	
-18 to +4	0 to 40	3 hours		8 days		8 days	

**Note:** Joint cure schedule is the necessary time to allow before pressurising the system. In damp or humid weather, allow 50% more cure time.

\*\*These figures are estimates based on our laboratory tests. Due to the many variables in the field, these figures should be used as a general guide only.

## ADDITIONAL INFORMATION

The list below identifies some industry standards in use today regarding manufacturing quality control and proper installation of PVC sewer pipe. To order a copy of any of these standards, please contact the appropriate organization using the addresses presented at the bottom of the list.

### Standards

AASHTO M278	Class PS46 Polyvinyl Chloride (PVC) Piping Systems for Subsurface Drainage of Transportation Facilities
AASHTO M304	Polyvinyl Chloride (PVC) Ribbed Drain Pipe and Fittings Based on Controlled Inside Diameter
ASTM D2321	Underground Installation of Flexible Thermoplastic Sewer Pipe
ASTM D3034	Type PSM Polyvinyl Chloride (PVC) Sewer Pipe and Fittings
ASTM F679	Polyvinyl Chloride (PVC) Large Diameter Plastic Gravity Sewer Pipe and Fittings
ASTM F794	Polyvinyl Chloride (PVC) Ribbed Gravity Sewer Pipe and Fittings Based on Controlled Inside Diameter
AWWA C605	Underground Installation of Polyvinyl Chloride (PVC) Pressure Pipe & Fittings for Water
AWWA C905	Polyvinyl Chloride (PVC) Pressure Pipe & Fittings 14" through 48" (350 mm through 1200 mm)
BNQ 3624-130	Piping – PVC Plastic Rigid Pipe & Fittings, 150 mm in Diameter or Smaller for Underground Sewage Application
BNQ 3624-135	Piping – PVC Plastic Rigid Pipe & Fittings, 200 mm in Diameter or Greater, for Underground Sewage Application
BNQ 3624-250	Piping – PVC Plastic Rigid Pipe & Fittings, for Conveyance and Distribution of Water Under Pressure

CSA B137.3	Rigid Polyvinyl Chloride (PVC) Pipe for Pressure Applications
CSA B181.2	PVC Drain, Waste and Vent Pipe & Pipe Fittings
CSA B182.1	Plastic Drain and Sewer Pipe and Fittings
CSA B182.11	Recommended Practice for the Installation of Thermoplastic Drain, Storm & Sewer Pipe and Fittings
CSA B182.2	PVC Sewer Pipe and Fittings
CSA B182.4	Profile (Ribbed) PVC Sewer Pipe & Fittings
UNI-B-6	Recommended Practice for Low-Pressure Air Testing of Installed Sewer Pipe
UNI-PUB-6	Installation Guide for PVC Sewer Pipe
UNI-PUB-7	External Corrosion of Underground Water Distribution Piping Systems
UNI-TR-1	Deflection: The Pipe/Soil Mechanism
UNI-TR-6	PVC Force Main Design

## Abbreviations

AASHTO	American Association of State Highway and Transportation Officials
ASTM	American Society for Testing and Materials
AWWA	American Water Works Association
BNQ	Bureau de Normalisation du Quebec
CSA	Canadian Standards Association
UNI-Bell	Uni-Bell PVC Pipe Association

## Addresses

### **CSA International**

178 Rexdale Boulevard  
Toronto, Ontario, M9W 1R3  
Ph: (416) 747-4000  
Fx: (416) 747-4149

### **American Society for Testing and Materials**

100 Barr Harbor Drive  
West Conshohocken, PA, USA 19428-2959  
Ph: (610) 832-9500  
Fx: (610) 832-9555

### **Uni-Bell PVC Pipe Association**

2711 LBJ Freeway, Suite 1000  
Dallas, Texas, USA 75234  
Ph: (972) 243-3902, Fx: (972) 243-3907

### **American Association of State Highway & Transportation Officials**

444 North Capitol St., N.W., Ste. 249  
Washington, DC, USA 20001  
Ph: (202) 624-5800  
Fx: (202) 624-5806

### **American Water Works Association**

6666 West Quincy Avenue,  
Denver, Colorado, USA 80235  
Ph: (303) 794-7711  
Fx: (303) 794-7310

### **Bureau de Normalisation du Québec Parc Technologique du Québec Métropolitain**

333, Rue Franquet  
Sainte-Foy (Québec) G1P 4C7  
Ph: (418) 652-2238  
Toll Free: (800) 386-5114  
Fx: (418) 652-2292

## Unit Conversion

Parameter	S.I.	x	Factor	=	U.S.
Length	mm	x	0,0394	=	inch
	cm	x	0,3937	=	inch
	m	x	32,808	=	feet
Mass	kg	x	22,046	=	lb
	kg/m	x	0,6720	=	lb/ft
Volume	L	x	0,2642	=	U.S. Gal.
Pressure	kPa	x	0,3346	=	ft H-20
	kPa	x	0,2924	=	in Hg
	kPa	x	0,1450	=	psi
Energy	J	x	0,7376	=	ft-lb
	kg-m	x	72,230	=	ft-lb
Torque	N-m	x	0,7376	=	ft-lb
Force	N	x	0,2248	=	lb
Temperature:	$\text{deg. C} = 0,5556) \times (\text{deg. F} - 32)$ $\text{deg. F} = (1,8 \times \text{deg. C}) + 32$				













# SALES AND CUSTOMER SERVICE

## IPEX Inc.

Toll free: (866) 473-9462

[ipexna.com](http://ipexna.com)

## About the IPEX Group of Companies

As leading suppliers of thermoplastic piping systems, the IPEX Group of Companies provides our customers with some of the world's largest and most comprehensive product lines. IPEX products are backed by more than 50 years of experience. With state-of-the-art manufacturing facilities and distribution centers across North America, we have earned a reputation for product innovation, quality, end-user focus and performance.

Markets served by IPEX group products are:

- Electrical systems
- Telecommunications and utility piping systems
- PVC, CPVC, PP, PVDF, PE, ABS, and PEX pipe and fittings
- Industrial process piping systems
- Municipal pressure and gravity piping systems
- Plumbing and mechanical piping systems
- Electrofusion systems for gas and water
- Industrial, plumbing and electrical cements
- Irrigation systems

Products are manufactured by IPEX Inc.

Ultra-Rib®, Ring-Tite®, Ultra-X2™ & Enviro-Tite® are trademarks of IPEX Branding Inc.

[ipexna.com](http://ipexna.com)

This literature is published in good faith and is believed to be reliable. However, it does not represent and/or warrant in any manner the information and suggestions contained in this brochure. Data presented is the result of laboratory tests and field experience.

A policy of ongoing product improvement is maintained. This may result in modifications of features and/or specifications without notice



**IPEX**  
by **alixis**

IGMNAIP140208R1C  
© 2019 IPEX MN003C