

USER AND INSTALLER MANUAL



VB0309



VB0308

A110H65RT A110H65RS

V110H65RT V110H65RS

A130H65RT A130H65RS

V130H65RT V130H65RS

A130E65RT A130E65RS

V130E65RT V130E65RS

A150H75NT A150H75NS

V150H75NT V150H75NS

A150E75NT A150E75NS

V150E75NT V150E75NS

A160H75RT A160H75RS

V160H75RT V160H75RS

A160H65RT A160H65RS

V160H65RT V160H65RS

A160E75RT A160E75RS

V160E75RT V160E75RS

A160E65RT A160E65RS

V160E65RT V160E65RS

REGISTER YOUR PRODUCT ONLINE AT:

www.venmar.ca/register-your-product.html or

www.vanee.ca/en/register-your-product.html

For additional information, visit www.venmar.ca or www.vanee.ca

INSTALLER: READ THESE INSTRUCTIONS

SAVE THEM FOR USER

RESIDENTIAL USE ONLY



7 72371 15730 9

23831 REV. 02

Please take note that this manual uses the following symbols to emphasize particular information:

⚠WARNING

Identifies an instruction which, if not followed, might cause serious personal injuries including possibility of death.

CAUTION

Denotes an instruction which, if not followed, may severely damage the unit and/or its components.

NOTE: Indicates supplementary information needed to fully complete an instruction.

LIMITATION

For residential (domestic) installation only. Installation work and electrical wiring must be done by a qualified person in accordance with all applicable codes and standards, including fire-rated construction codes and standards.

⚠WARNING

TO REDUCE THE RISK OF FIRE, ELECTRIC SHOCK, OR INJURY TO PERSON(S) OBSERVE THE FOLLOWING:

1. Use this unit only in the manner intended by the manufacturer.
2. Before servicing or cleaning this unit, disconnect power cord from electrical outlet.
3. This unit is not designed to provide combustion and/or dilution air for fuel-burning appliances.
4. When cutting or drilling into a wall or ceiling, do not damage electrical wiring and other hidden utilities.
5. Do not use this unit with any solid-state speed control device other than those specified in section 3.1.
6. This unit must be grounded. The power supply cord has a 3-prong grounding plug for your personal safety. It must be plugged into a mating 3-prong grounding receptacle, grounded in accordance with the national electrical code and local codes and ordinances. Do not remove the ground prong. Do not use an extension cord.
7. Do not install in a cooking area or connect directly to any appliances.
8. Do not use to exhaust hazardous or explosive materials and vapors.
9. When performing installation, servicing or cleaning this unit, it is recommended to wear safety glasses and gloves.
10. When applicable local regulation comprises more restrictive installation and/or certification requirements, the aforementioned requirements prevail on those of this document and the installer agrees to conform to these at his own expenses.

CAUTION

1. To avoid prematurely clogged filters, turn the unit OFF during construction or renovation.
2. Please read specification label on product for further information and requirements.
3. Be sure to duct air outside - Do not intake/exhaust air into spaces within walls or ceiling or into attics, crawl spaces, or garage. Do not attempt to recover the exhaust air from a dryer or a range hood.
4. Intended for residential installation only in accordance with the requirements of NFPA 90B (for a unit installed in U.S.A.) or Part 9 of the National Building Code of Canada (for a unit installed in Canada).
5. Do not run any air ducts directly above or within 2 ft (0.61 m) of a furnace or its supply plenum, boiler, or other heat producing appliance. If a duct has to be connected to the furnace return plenum, it must be connected 10' (3.1 m) away from plenum's connection to the furnace.
6. The ductwork is intended to be installed in compliance with all applicable local and national codes.
7. When leaving the house for a long period of time (more than two weeks), a responsible person should regularly check if the unit operates adequately.
8. If the ductwork passes through an unconditioned space (e.g.: attic), the unit must operate continuously except when performing maintenance and/or repair. Also, the ambient temperature of the house should never drop below 18°C (65°F).
9. At least once a year, the unit mechanical and electronic parts should be inspected by qualified service personnel.
10. Do not use your unit during construction or renovation of your house or when sanding drywall. Certain types of dust and vapors may damage your system.
11. Make sure at all times that the outside intake and exhaust hoods are free from any snow during the winter season. It is important to check your unit during a big snow storm, so it doesn't draw in any snow. If this is the case, please turn the unit OFF for a few hours.
12. Since the electronic control system of the unit uses a microprocessor, it may not operate correctly because of external noise or very short power failure. If this happens, unplug the unit and wait approximately 10 seconds. Then, plug the unit in again.
13. Do not make excessive use of fragrance appliances or chemicals since some may damage the unit components material.

TABLE OF CONTENTS

1. TECHNICAL DATA.....	4
1.1 AIR DISTRIBUTION (NORMAL OPERATION).....	4
2. INSTALLATION.....	4
2.1 LOCATING AND MOUNTING THE UNIT.....	4
2.2 INSTALLING THE DUCTWORK AND THE REGISTERS.....	6
2.2.1 FULLY DUCTED SYSTEM (T-1).....	6
2.2.2 EXHAUST DUCTED SYSTEM (T-2).....	6
2.2.3 SIMPLIFIED INSTALLATION (T-4).....	7
2.3 CONNECTING THE DRAIN (HRV ONLY).....	8
2.4 INSTALLING DUAL EXTERIOR HOOD USING TANDEM® TRANSITION KIT (OPTIONAL).....	9
2.5 INSTALLING THE EXTERIOR HOODS.....	9
2.6 CONNECTING THE DUCTS TO THE UNIT.....	9
2.6.1 DUCTS CONNECTION.....	10
3. CONNECTIONS.....	11
3.1 ELECTRICAL CONNECTION TO OPTIONAL MAIN WALL CONTROL.....	11
3.1.1 ELECTRICAL CONNECTION TO DEHUMIDISTAT OR AUTOMATIC OPTIONAL MAIN WALL CONTROL.....	11
3.1.2 ELECTRICAL CONNECTION TO ADVANCED OPTIONAL MAIN WALL CONTROL.....	11
3.2 ELECTRICAL CONNECTION TO OPTIONAL AUXILIARY WALL CONTROL.....	12
3.3 CONNECTION TO THE FURNACE/AHU.....	12
4. WIRING DIAGRAM.....	13
5. UNIT AUTO-BALANCING.....	14
6. USING THIS UNIT.....	14
6.1 YOUR VENTILATION SYSTEM.....	14
6.2 INTEGRATED CONTROL.....	14
7. SERVICE PARTS.....	15
8. INSTALLER'S TROUBLESHOOTING.....	17
9. MAINTENANCE.....	20
9.1 QUARTERLY.....	20
9.2 ANNUAL (AT FALL).....	21
10. USER'S TROUBLESHOOTING.....	21
11. WARRANTY.....	22

1. TECHNICAL DATA

1.1 AIR DISTRIBUTION (NORMAL OPERATION)

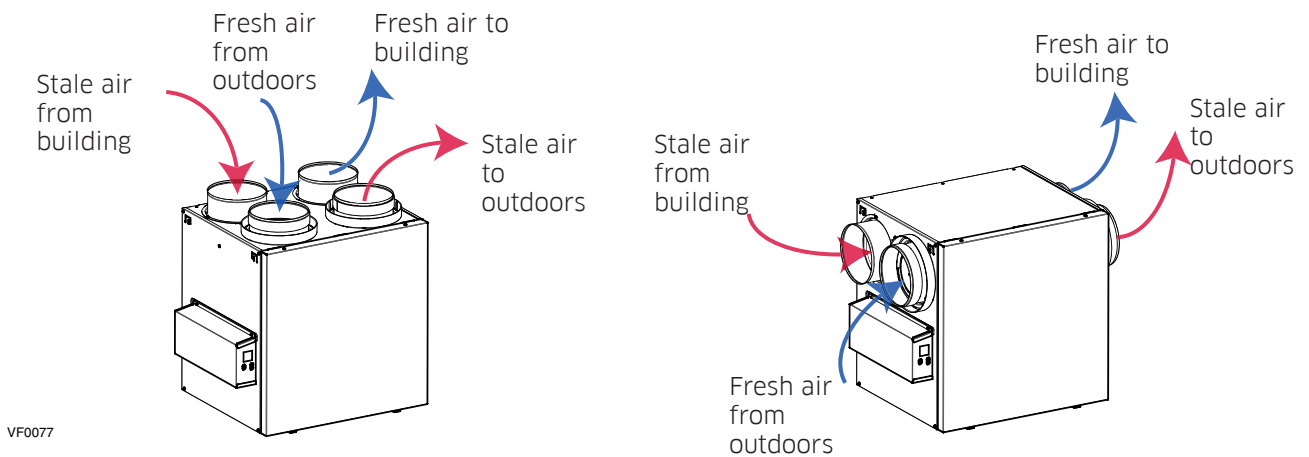

NOTE: The dimensions, performance charts, defrost cycle tables and specifications are listed on the specification sheets of the unit.

Visit our website at www.venmar.ca or www.vanee.ca.

2. INSTALLATION

⚠ WARNING

When performing installation, servicing or cleaning the unit, it is recommended to wear safety glasses and gloves.

2.1 LOCATING AND MOUNTING THE UNIT

Choose an appropriate location for the unit:

- Within an area of the house where the ambient temperature is kept between 10°C (50°F) and 60°C (140°F);
- Away from living areas (dining room, living room, bedroom), if possible;
- So as to provide easy access to the interior cabinet for maintenance, and to the control panel on the side of the unit;
- Close to an exterior wall, so as to limit the length of the insulated flexible ducts to and from the unit;
- HRV units only: close to a drain. If no drain is close by, use a pail to collect run-off;
- Away from hot chimneys, electrical panel and other fire hazards;
- Within 6 feet of a power source (standard outlet).

2.1 LOCATING AND MOUNTING THE UNIT (CONT'D)

Suspended to the joists or trusts:

- Slightly bend the brackets on the unit to insert the provided chains.
- Hang the unit to the joists using the provided chains. Springs are not required.
- Always make sure that the unit is no more than 1/4" off level.

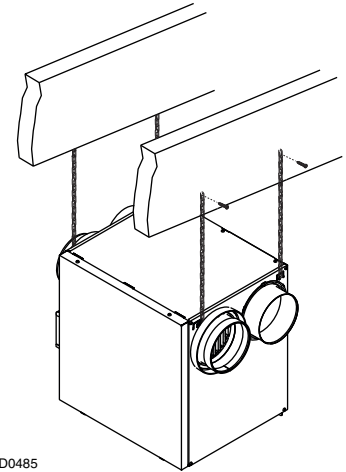

VD0485

OR

Wall mounted:

- Choose the appropriate location(s) for the mounting brackets (see illustration below) according to stud(s) position.
- Insert the provided brackets under the unit frame (see illustration hereafter).
- Fix the bracket using the screw no. 8 x 3/8".
- Using the 4 no. 8 x 1 1/2" screws provided, secure the unit to the wall making sure that the 4 screws engage into a stud.
- Always make sure that the unit is no more than 1/4" off level.

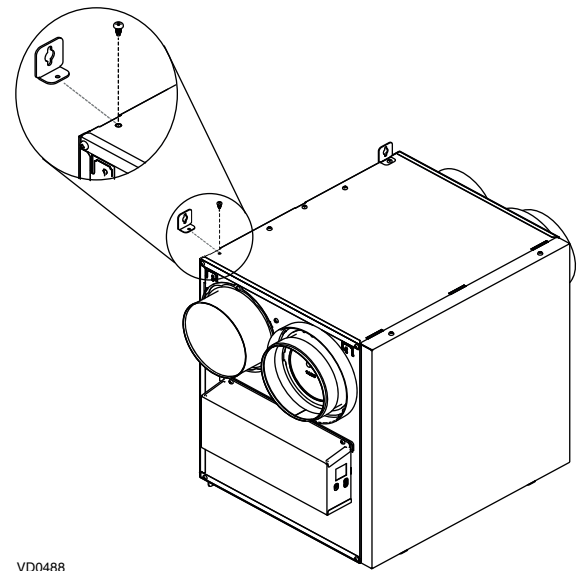

VD0488

INSTALLATION WITH 2 BRACKETS

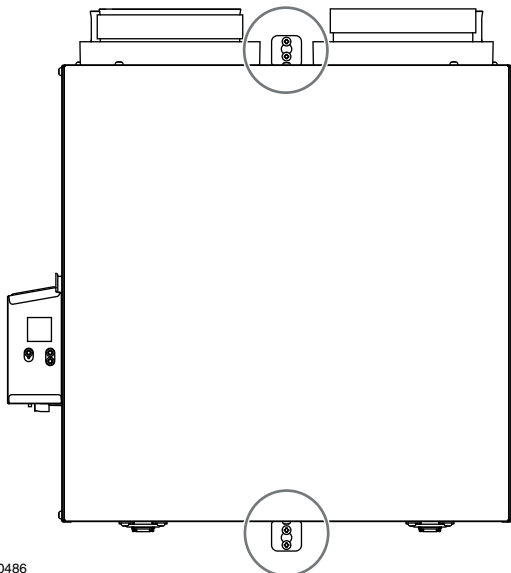

VD0486

INSTALLATION WITH 4 BRACKETS

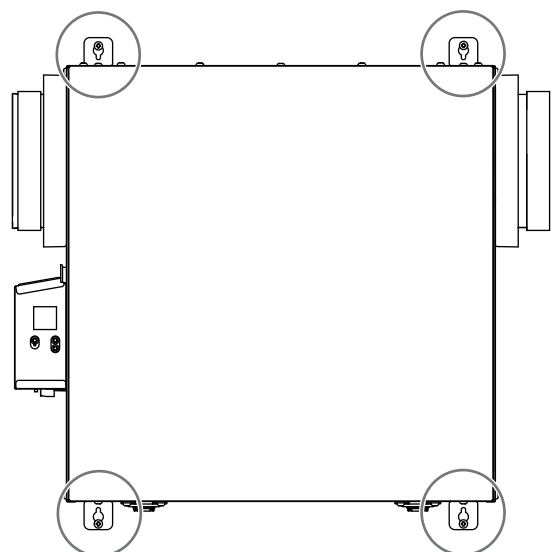

VD0487

2.2 INSTALLING THE DUCTWORK AND THE REGISTERS

⚠ WARNING

Never install a stale air exhaust register in a room where there is a combustion device, such as a gas furnace, a gas water heater or a fireplace.

2.2.1 FULLY DUCTED SYSTEM (T-1)

STALE AIR EXHAUST DUCTWORK:

- Install registers in areas where contaminants and humidity are produced: kitchen, bathrooms, laundry room, etc.
- Install registers on an interior wall, 6 to 12 inches away from the ceiling OR in the ceiling.
- Install the kitchen register at least 4 feet away from the range.
- Bathroom fans and range hoods can be used to better exhaust stale air.
- Homes with more than one level require at least one exhaust register at the highest level.

FRESH AIR DISTRIBUTION DUCTWORK:

- Install registers in bedrooms, dining room, living room and basement.
- Install registers in the ceiling OR high on the walls with the airflow directed towards the ceiling.
- If a register must be installed in the floor, direct the airflow up the wall.

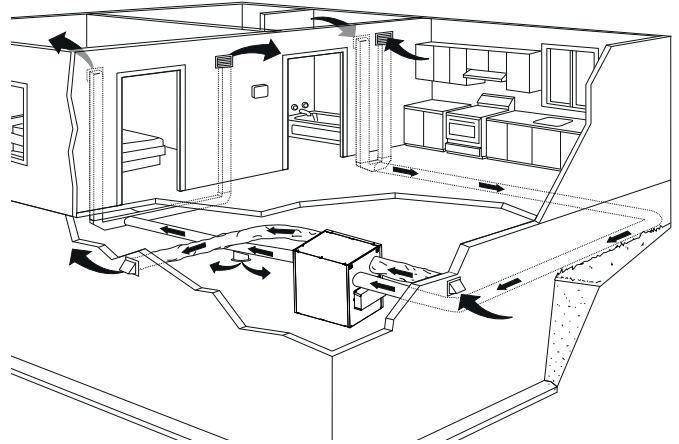

NOTE: For this type of configuration, the T-1 option must be selected on the LCD screen when auto-balancing the unit.

2.2.2 EXHAUST DUCTED SYSTEM (T-2)

⚠ WARNING

When performing duct connection to the furnace/AHU, installation must be done in accordance with all applicable codes and standards. Please refer to your local building code.

STALE AIR EXHAUST DUCTWORK:

Same as for Fully Ducted System, described on point 2.2.1.

FRESH AIR DISTRIBUTION:

- Connect the fresh air distribution duct of the unit to the furnace/AHU return duct at least 10 feet away from the furnace/AHU (A+B)*.

* This 10-ft. distance applies only in areas where the outside temperature falls below the freezing point 0°C (32°F).

NOTE: The furnace/AHU blower operation can be synchronized with the unit (see Section 3.3). It is recommended, but not essential that the furnace/AHU blower runs when the unit is in operation.

NOTE: For this type of configuration, the T-2 option must be selected on the LCD screen when auto-balancing the unit.

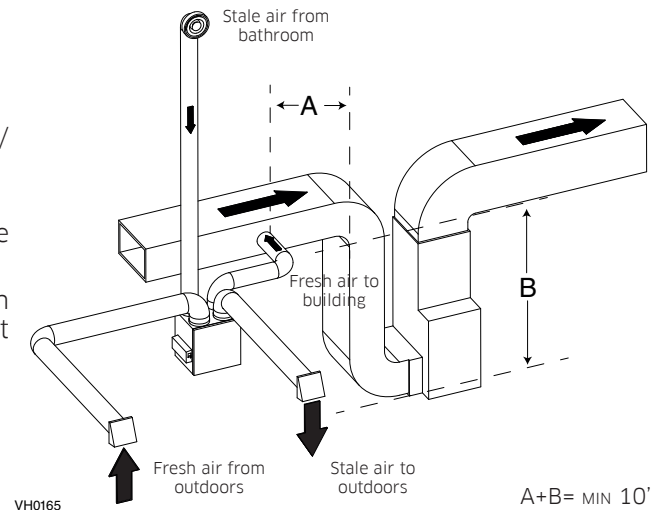

ALTERNATE INSTALLATION (T-3):

Unit should be synchronized with AHU/furnace operation to avoid condensation and mold growth in furnace/AHU distribution ducting if cooling mode of furnace/AHU is used.

CAUTION

This configuration is not recommended with high velocity furnace.

NOTE: For this type of configuration, the T-3 option must be selected on the LCD screen when auto-balancing the unit.

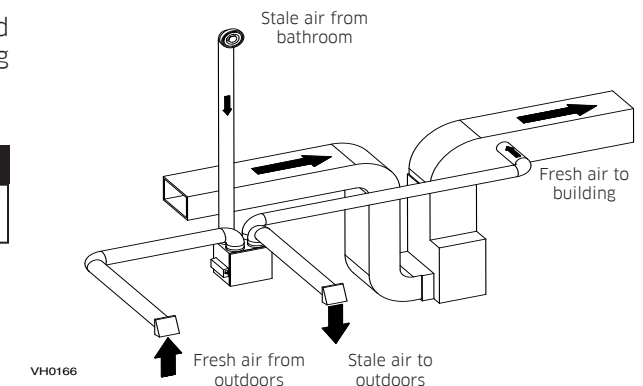

2.2.3 SIMPLIFIED INSTALLATION (T-4)

CAUTION

For this type of installation, the furnace/AHU must always be synchronized with the unit. See Section 3.3.

⚠ WARNING

When performing duct connection to the furnace/AHU, installation must be done in accordance with all applicable codes and standards. Please refer to your local building code.

Fresh air and exhaust air flow through the furnace/AHU ducts, which simplifies the installation.

The use of bathroom fans and a range hood is suggested to exhaust stale air.

STALE AIR EXHAUST DUCTWORK:

Connect the stale air intake port of the unit to the furnace return duct at least 3 feet ahead of the fresh air distribution from the unit.

FRESH AIR DISTRIBUTION:

Connect the fresh air distribution duct of the unit to the furnace return duct at least 10 feet away from the furnace (A+B)*.

* This 10-ft. distance applies only in areas where the outside temperature falls below the freezing point 0°C (32°F).

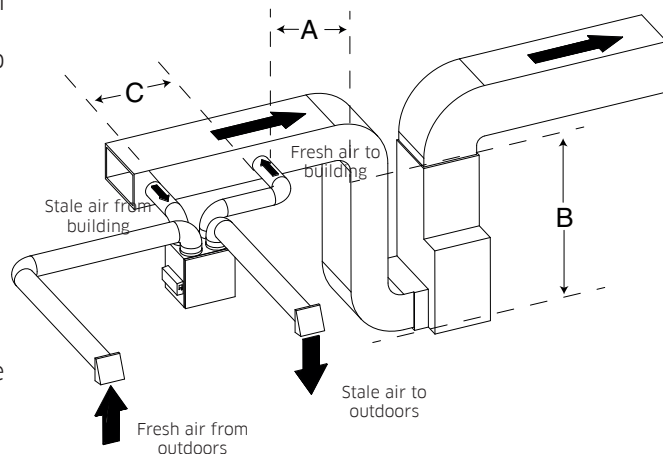

VH0167

$$A+B = \text{MIN } 10'$$

$$C = 3'$$

NOTE: For this type of configuration, the T-4 option must be selected on the LCD screen when auto-balancing the unit.

ALTERNATE INSTALLATION (T-5):

Unit should be synchronized with AHU/Furnace operation to avoid condensation and mold growth in furnace/AHU distribution ducting if cooling mode of furnace/AHU is used.

CAUTION

This configuration is not recommended with high velocity furnace.

NOTE: For this type of configuration, the T-5 option must be selected on the LCD screen when auto-balancing the unit.

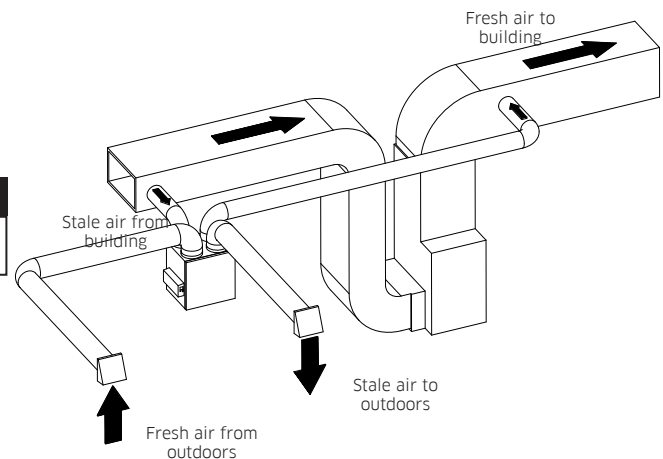

VH0168

2.3 CONNECTING THE DRAIN (HRV ONLY)

CAUTION

A drain hose (included) must be installed on these units.

- Cut the appropriate length of drain tubing (see illustrations below).
- Connect the tubing to the provided adaptor.
- Make a water trap loop in the tube to prevent the unit from drawing unpleasant odors from the drain source.
- Add water in the loop to prevent noise or hiss.
- Make sure there is a distance of at least 2" between the unit and the tubing loop (see illustration below).
- Using the tie wrap provided, attach the tubing as illustrated below.
- Run the tube to the floor drain or to an alternate drain pipe or pail.
- IMPORTANT: If using a pail to collect water, place the tube end approximately 1" inside the pail in order to prevent water from being drawn back up into the unit.

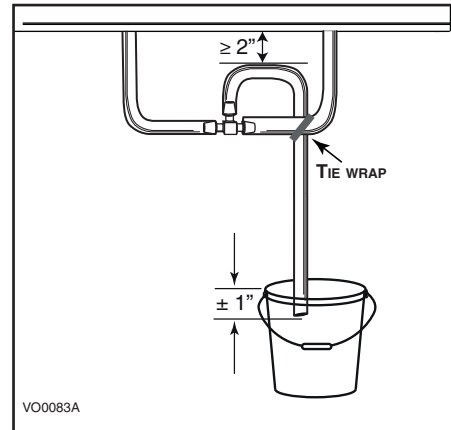
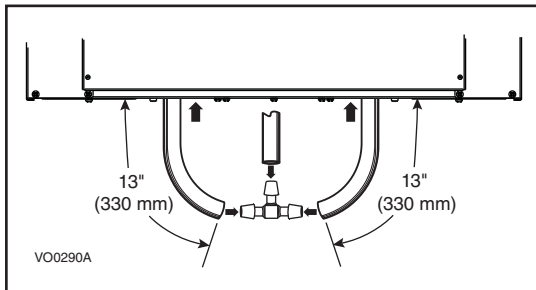

2.4 INSTALLING DUAL EXTERIOR HOOD USING TANDEM® TRANSITION KIT (OPTIONAL)

For units set at 110 CFM or less, a Tandem transition kit can be used instead of 2 exterior hoods; but take into account this device will generate approximately an additional 0.2 in. w.g. static pressure depending on the installation.

The minimum joist opening needed to install the Tandem® transition is 9¾". The maximum height of the Tandem transition is 8¾".

To connect the insulated flexible ducts to the Tandem transition (Exhaust air to outdoors and Fresh air from outdoors), follow the instructions included with the Tandem transition kit (part no.14690).

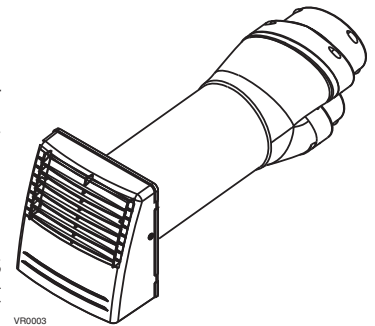

2.5 INSTALLING THE EXTERIOR HOODS

Choose an appropriate location for the exterior hoods:

- At least 6 feet between both hoods to avoid cross-contamination
- At least 18 inches away from the ground

⚠ WARNING

Make sure the intake hood is at least 6 feet away from any of the following:

- Dryer exhaust, high efficiency furnace vent, central vacuum vent
- Gas meter exhaust, gas barbecue-grill
- Any exhaust from a combustion source
- Garbage bin and any other source of contamination.

Refer to illustration at right for proper connection method of the insulated ducts to the hoods. An “Anti-Gust Intake Hood” should be installed in regions where a lot of snow is expected to fall.

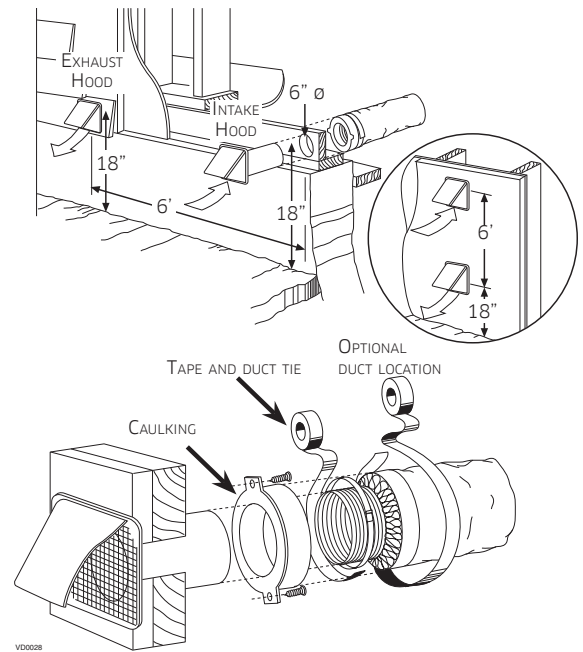

2.6 CONNECTING THE DUCTS TO THE UNIT

CAUTION

- If ducts have to go through an unconditioned space (e.g.: attic), always use insulated ducts.
- Do not use screws to connect the ducts or transitions to the ports.

INSULATED FLEXIBLE DUCTS

Use the following procedure to connect the insulated flexible ducts to the ports of the unit (exhaust to outside and fresh air from outside).

1. Expose the flexible duct by pulling back the insulation, and place it **over** the inner port ring.
2. Attach the flexible duct to the port using a tie wrap.
3. Seal the joint using duct tape.
4. Pull the insulation and vapor barrier over the joint, tuck them **between the inner and outer rings** of the double collar and fasten them in place using duct tape.

CAUTION

Avoid tearing the vapor barrier on the insulated ducts during installation to avoid condensation within the ducts.

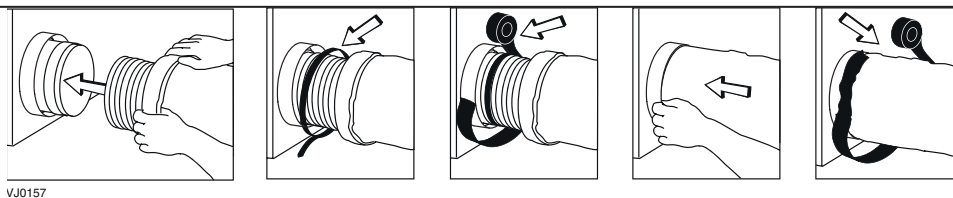

VJ0157

TRANSITIONING TO 6-IN. DUCTS (FOR 110, 130 AND 150 CFM UNITS ONLY)

If using 6-in. ducts, install 5-in. to 6-in. transitions on the ports, and secure using duct tape only. If rigid ducting is used, install a 12-in. section of flexible duct between the transition and the rigid ducting (see above).

RIGID DUCTS

To prevent potential water leakage in cold side rigid ducting insulation, seal all rigid ducting joints with duct tape. To avoid transmission of vibrations, always use a 12-inch section of flexible duct to connect rigid ducts to the unit. To connect insulated rigid ducts to the unit (cold side) using insulated flexible ducts, follow instructions in section 2.5. To connect regular rigid ducts (warm side) to the unit using non-insulated flexible ducts, use a tie wrap.

NOTE: It is recommended to use 6" ducting instead of 5" ducting for 150H75NT, 150H75NS, 150E75NT and 150E75NS units if required airflow is over 130 CFM. It will prevent having too high static pressure in the ducting.

2.6.1 DUCTS CONNECTION

IMPORTANT: Make sure to connect ducting as illustrated below to get airflows reading accuracy. Correct installation will also allow proper drainage of water that may accumulate in ducting.

CORRECT INSTALLATION

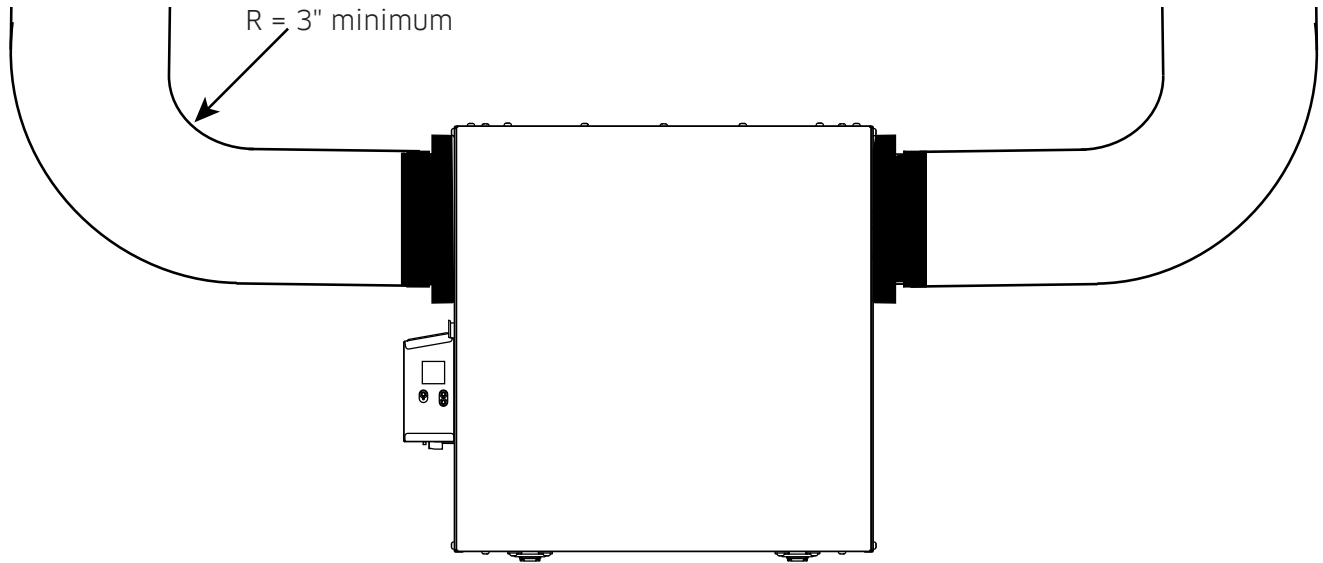

VD0489

CAUTION

Ducting must not be too crushed. Otherwise, airflows reading accuracy will be affected.

CAUTION

Insulated ducts must have the same diameter as the ports to ensure proper drainage of water that may accumulate in ducts.

INCORRECT INSTALLATION

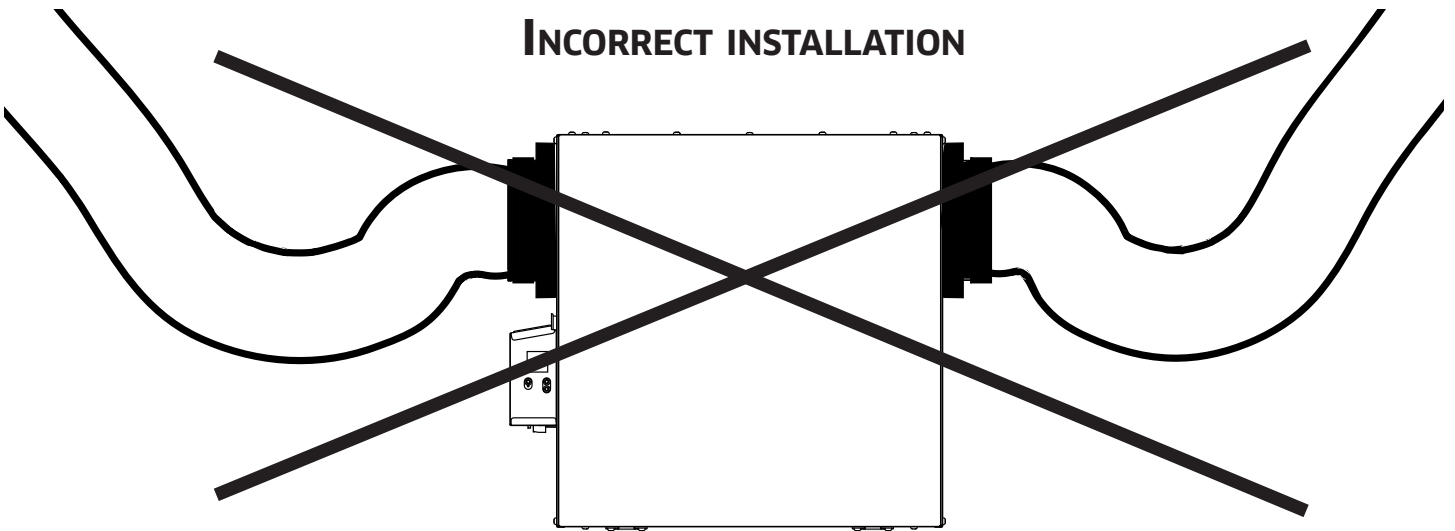

VD0490

3. CONNECTIONS

3.1 ELECTRICAL CONNECTION TO OPTIONAL MAIN WALL CONTROL

⚠ WARNING

Always disconnect the unit before making any connections. Failure to cut power could result in electrical shock or damage to the wall control or electronic module inside the unit.

CAUTION

Never install more than one optional main wall control per unit. Make sure that the wires do not short-circuit between themselves or by touching any other components on the wall control. Avoid poor wiring connections. To reduce the risk of electrical interference (noise), do not run wall control wiring next to control contactors or near light dimming circuits, electrical motors, dwelling/building power or lighting wiring or power distribution panel.

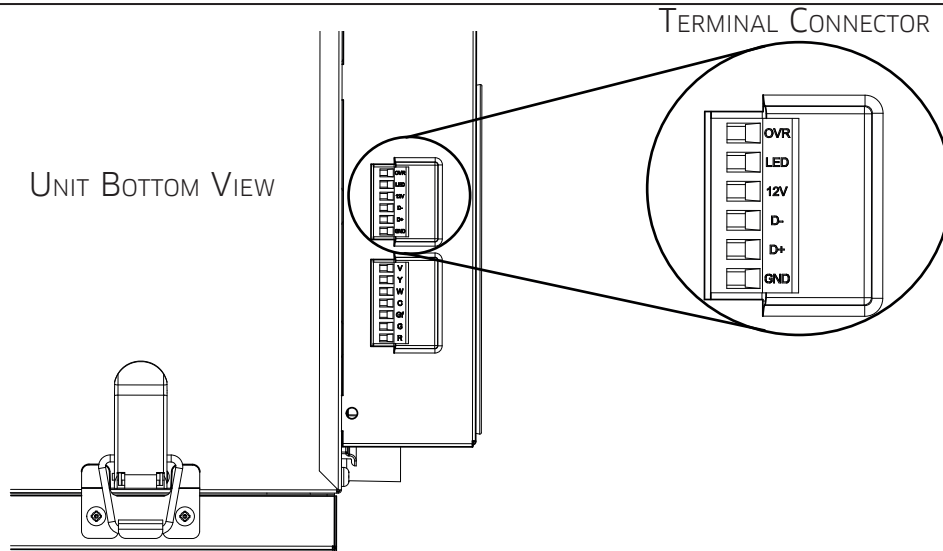

HD0491

Use the terminal connector included to perform the electrical connection for optional main wall control. Check if all wires are correctly inserted in their corresponding holes in the terminal connector. Use screws to fix wires in the terminal connector. Once the wall control connections have been made, insert the terminal connector in the electrical compartment.

NOTE: For information about the operation of the wall control, refer to the corresponding Installation and User Guide, available at www.vanee.ca or www.venmar.ca.

3.1.1 ELECTRICAL CONNECTION TO DEHUMIDISTAT OR AUTOMATIC OPTIONAL MAIN WALL CONTROL

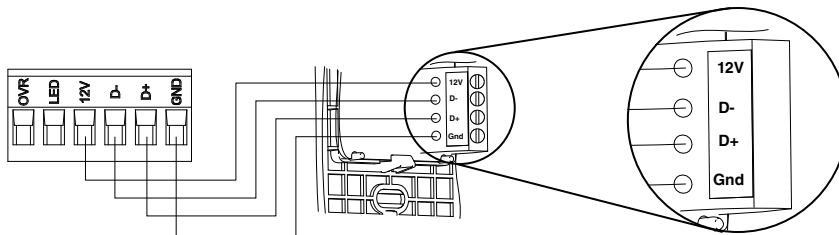

VC0241

3.1.2 ELECTRICAL CONNECTION TO ADVANCED OPTIONAL MAIN WALL CONTROL

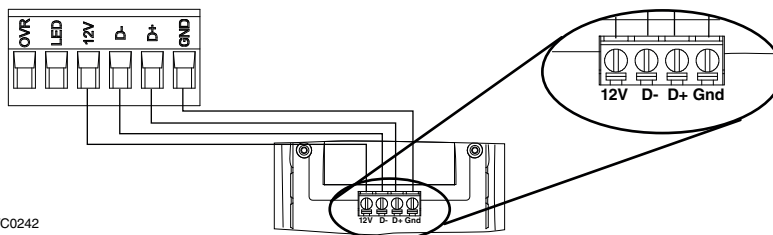

VC0242

3. CONNECTIONS (CONT'D)

3.2 ELECTRICAL CONNECTION TO OPTIONAL AUXILIARY WALL CONTROL

3.2.1 ELECTRICAL CONNECTION TO 20-40-60 OPTIONAL AUXILIARY WALL CONTROL

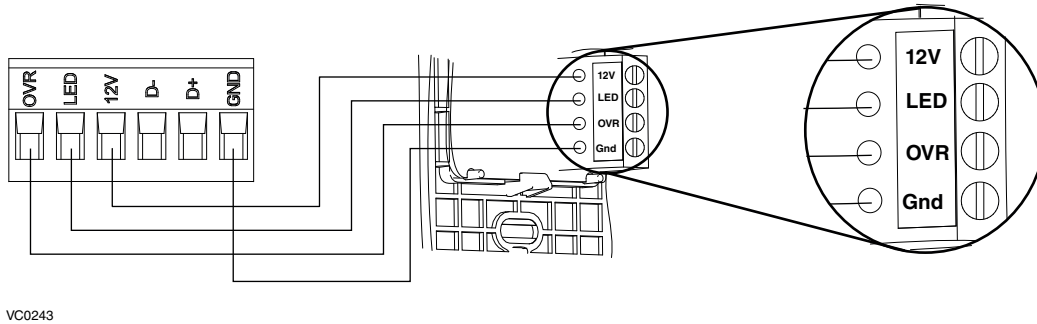

VC0243

When configuring OVR option on the LCD screen, choose among these 3 configurations: BAL (the unit remains balanced while providing maximum airflow), PER (the unit is slightly unbalanced since the distribution motor is in MAX speed while allowing maximum exhaust ventilation) and DIS (the unit is unbalanced since air distribution is constant despite a higher need in exhaust ventilation).

3.3 CONNECTION TO THE FURNACE/AHU

⚠ WARNING

Never connect a 120-volt AC circuit to the terminals of the furnace/AHU interlock (standard wiring). Only use the low voltage class 2 circuit of the furnace/AHU blower control.

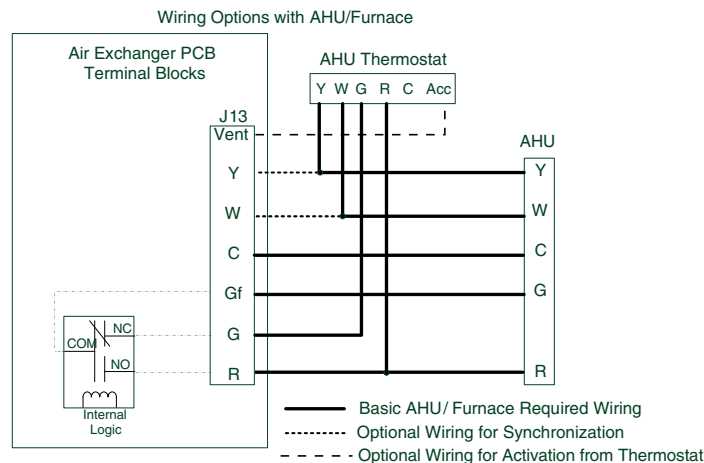

VE0432A

3.3.1 UNIT OPERATION USING A FURNACE/AHU THERMOSTAT

If the thermostat is equipped with an optional ventilation output, it is possible to use it to operate the unit. Choose among these 4 configurations: minimum (unit operating in MIN speed), intermittent (unit operating in MIN speed 20 min/h then as per INT configuration selection for 40 min), auto (unit operating according to outdoor temperature) and maximum (unit operating in MAX speed) in DRY option on the LCD screen when the VENT contact is activated. Refer to section 5 for more details.

NOTE: This dry contact option will override the main wall control so we do not recommend to use a wall control and the thermostat together.

3.3.2 UNIT INTERCONNECTION WITH FURNACE/AHU (R/C/G/Gf)

These connections must be done if you want the unit to force the furnace/AHU blower operation when ventilating.

NOTE: These connections are required for installation configuration T-4. Refer to section 2.2 for more details.

3.3.3 SYNCHRONIZATION WITH AHU FUNCTION

The Virtuo technology allows synchronizing the unit operation with the furnace/AHU operating time. It prevents unnecessary AHU operating time while providing a better air distribution.

NOTE: W and Y connections must be added to R and C connections to inform the unit that the furnace/AHU is running.

4. WIRING DIAGRAM

⚠ WARNING

- Risk of electric shocks. Before performing any maintenance or servicing, always disconnect the unit from its power source.
- This product is equipped with an overload protection (fuse). A blown fuse indicates an overload or a short-circuit situation. If the fuse blows, unplug the product and check the polarity and voltage output from the outlet. Replace the fuse as per the servicing instructions (refer to wiring diagram for proper fuse rating) and verify the product. If the replaced fuse blows, it may be a short-circuit and the product must be discarded or returned to an authorized service center for examination and/or repair.

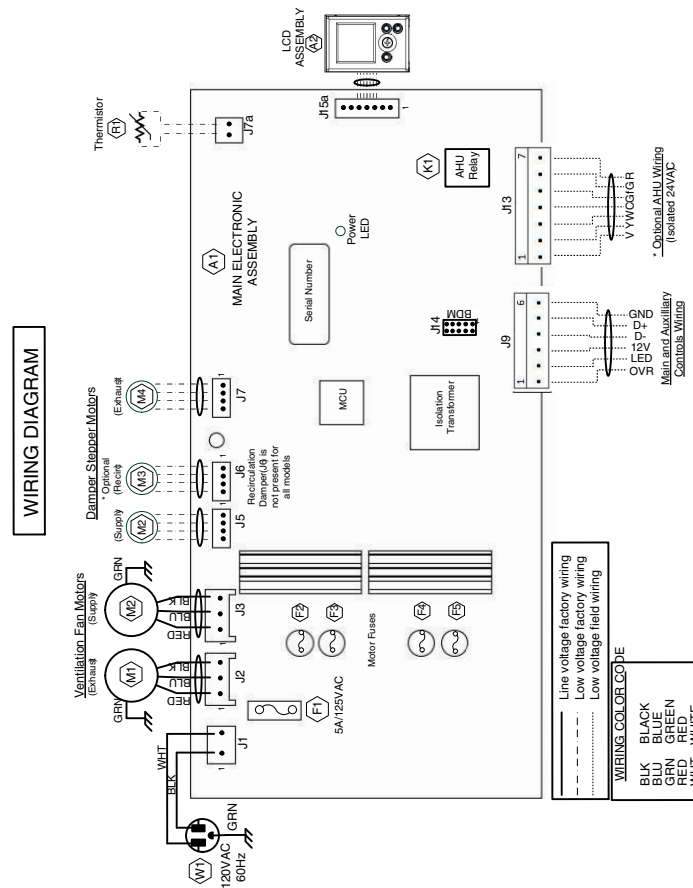
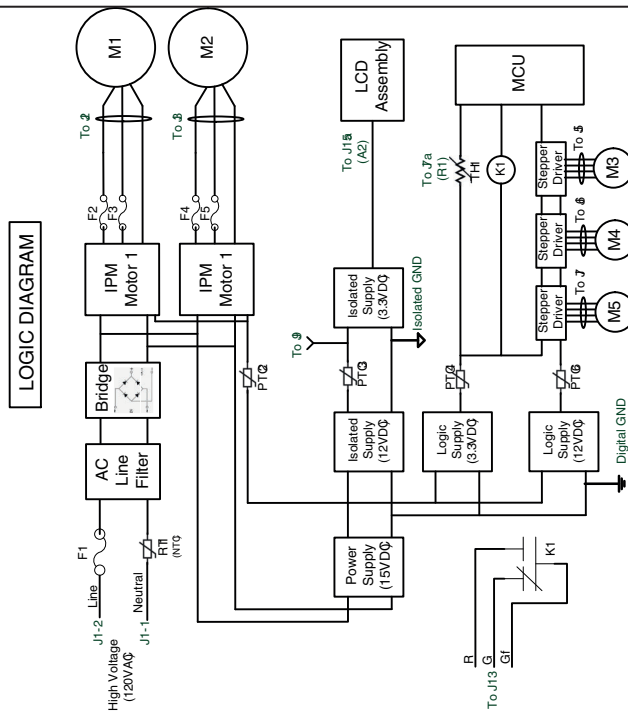

5. UNIT AUTO-BALANCING

PREPARATION

Follow these steps to ensure accurate measurements:

- Seal all the ductwork with tape. Close all windows and doors.
- Turn off all exhaust devices such as range hood, dryer and bathroom fans.
- If the installation is in any way connected to the ductwork of the cold air return of a furnace/air handler, make sure that the furnace/air handler blower is ON. If not, leave furnace/air handler blower OFF.

AUTO-BALANCING PROCEDURE

1. Plug the unit and wait for 90 seconds (airflow test).
2. The maximum CFM will display on the LCD screen. Use (+/-) to adjust the CFM and OK to confirm.
3. The minimum CFM will display on the LCD screen. Use (+/-) to adjust the CFM and OK to confirm.
4. INS will display on the LCD screen. Choose among T-1, T-2, T-3, T-4 or T-5 following the installation configuration (Refer to section 2.2 for more details).
5. If required, options can be configured. While on the CFG OPT screen, press on the OK button for 4 seconds. Use (+/-) to change the configuration and OK to confirm. If not required, press OK to skip this menu.

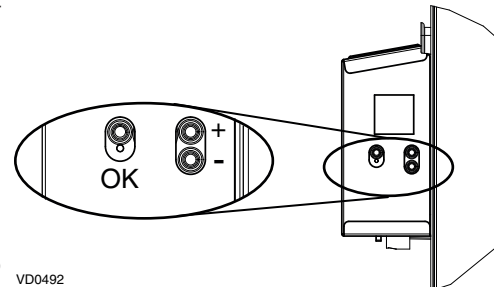

Options	Configurations available
DEF (Defrost)	DIS* (Discretion - defrost without speed variation for more comfort), PLU (Plus - extended defrost for colder areas)
INS (Installation)	T-1, T-2, T-3, T-4*, T-5 (Refer to section 2.2)
DRY (Dry contact)	MIN* (Minimum), INT (Intermittent), AUT (AUTO), MAX (Maximum) (Refer to section 3.3.1)
OVR (Override)	BAL* (Balanced), PER (Performance), DIS (Discretion) (Refer to section 3.2.1)
INT (Intermittent)	STB* (Standby - 20 min in MIN speed and 40 min in standby mode), REC** (Recirculation - 20 min in MIN speed and 40 min in recirculation mode)

* Factory setting

** REC (Recirculation) configuration is not available for 150H75NT, 150H75NS, 150E75NT and 150E75NS units.

6. Auto-balancing is completed.

NOTE: If no selection is confirmed within 10 minutes, the unit will exit the menu without saving any changes.

NOTE: If speed or configuration need to be modified, go to MIN, MAX or CFG using (+/-), then press on the OK button for 4 seconds. Use (+/-) to increase/decrease speed and OK to confirm.

If any change is made to the ducting, reset settings to restart the airflow test.

PROCEDURE TO RESET SETTINGS

Press on the OK and (-) buttons simultaneously for 4 seconds. Use (+/-) to select Yes or No and OK to confirm.

Then perform the auto-balancing procedure.

6. USING THIS UNIT

6.1 YOUR VENTILATION SYSTEM

This balanced ventilation unit is designed to provide fresh air to your home while exhausting stale, humid air. Thanks to its energy/heat recovery module, the unit recovers a large proportion of heat or energy that is part of indoor or outdoor air according to the seasons to improve comfort and energy efficiency during the heating and the cooling periods. With the Virtuo Air Technology™, this unit responds to the variations in its environment in an autonomous way, ensuring to provide a proper level of ventilation and air quality. This unit also features automatic modes (AUTO or SMART) that manage autonomously the required ventilation level as per indoor and/or outdoor conditions. In colder areas, the unit will perform, at intervals, recovery module discreet defrost to maintain performance and comfort.

6.2 INTEGRATED CONTROL

All units are equipped with an integrated control, located in front of the electrical compartment. For more convenience, these units can be controlled using an optional wall control or the furnace/AHU thermostat equipped with external fan activation.

MODE SELECTION

1. To change the mode, use (+/-) to access the Mode screen. Press OK to edit the mode and use (+/-) to change the mode (Standby, Min, Max).
2. Press OK to confirm selection. The airflows will be displayed for both MIN and MAX modes.

NOTE: If an optional auxiliary wall control or the furnace/AHU thermostat equipped with external fan activation is used, it overrides the integrated control.

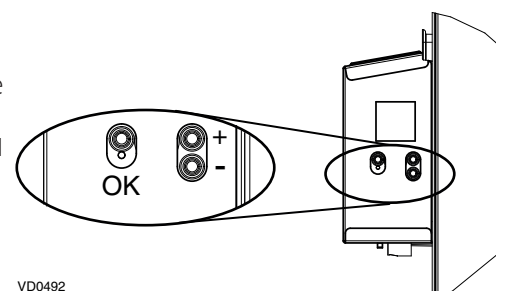

7. SERVICE PARTS

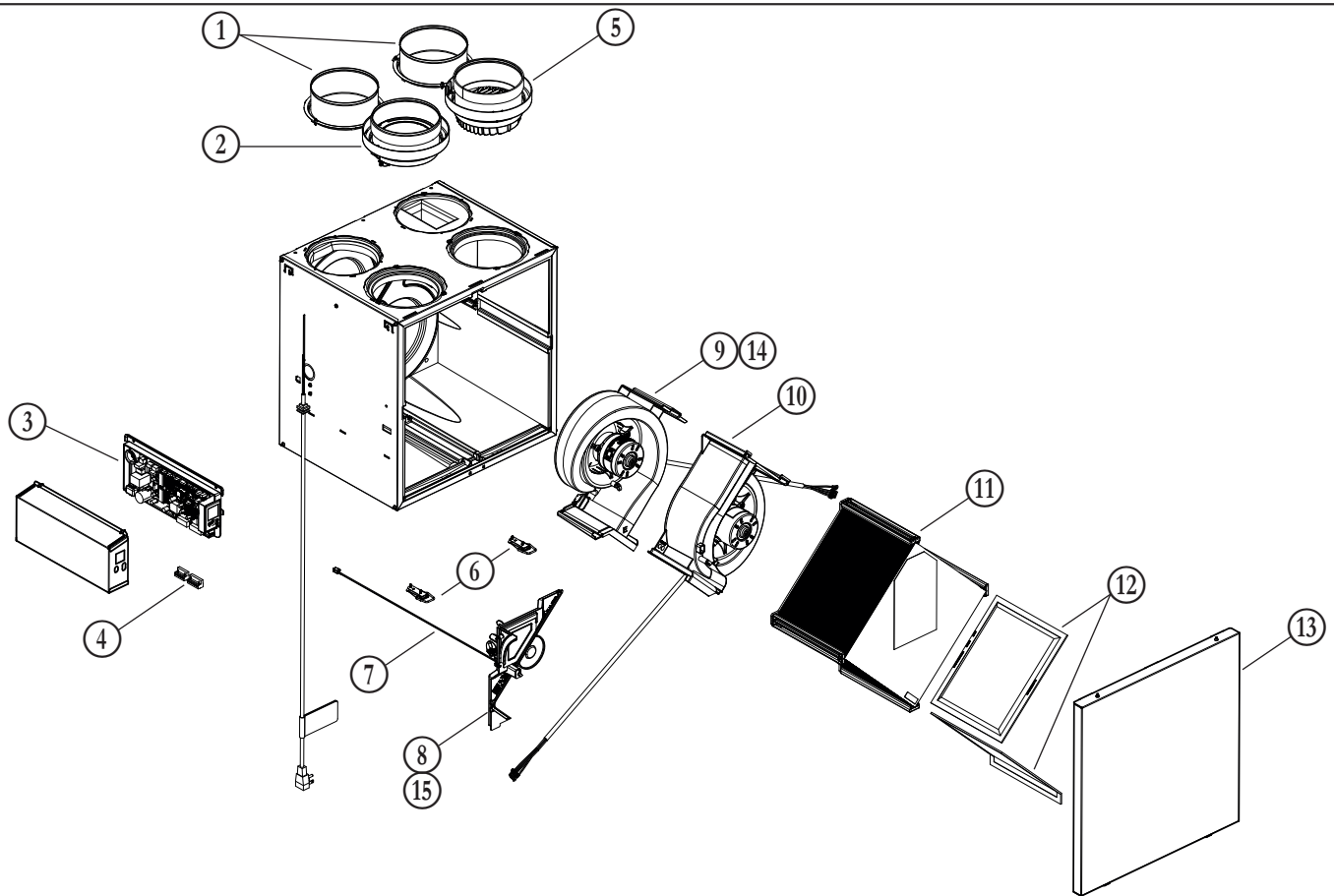

VL0086

ITEM	DESCRIPTION	PART NUMBER																		
			A/V110H65RT	A/V110H65RS	A/V130H65RT	A/V130H65RS	A/V130E65RT	A/V130E65RS	A/V160H65RT	A/V160H65RS	A/V160E65RT	A/V160E65RS	A/V160H75RT	A/V160H75RS	A/V160E75RT	A/V160E75RS	A/V150H75NT	A/V150H75NS	A/V150E75NT	A/V150E75NS
1	6" port warm side	SV66139					2	2	2	2										
	5" port warm side	SV66140	2	2	2												2	2		
2	6" metal port motorized damper	SV66135					1	1	1	1										
	5" metal port motorized damper	SV66136	1	1	1												1	1		
3	Electronic assembly	SV66144**	1	1	1	1	1	1	1	1	1	1	1	1	1	1	1	1	1	1
4	Terminal blocks	SV66145	1	1	1	1	1	1	1	1	1	1	1	1	1	1	1	1	1	1
5	6" exhaust port assembly	SV66137					1	1	1	1										
	5" exhaust port assembly	SV66138	1	1	1												1	1		
6	Door latches and keepers for door	SV61218	1	1	1	1	1	1	1	1	1	1	1	1	1	1	1	1	1	1
7	Thermistor	SV66134	1	1	1	1	1	1	1	1	1	1	1	1	1	1	1	1	1	1
8	Recirculation damper with thermistor	SV66148	1	1	1	1	1	1	1	1	1	1	1	1	1					
9	Exhaust blower with damper	SV66142	1	1	1	1	1	1	1	1	1	1	1	1	1	1	1	1	1	1
10	Supply blower assembly	SV66141	1	1	1	1	1	1	1	1	1	1	1	1	1	1	1	1	1	1
11	Core ERV 65 %	SV66113				1			1											
	Core ERV 75 %	SV66114												1						1
	Core HRV 65 %	SV66115	1	1			1													
	Core HRV 75 %	SV66116										1						1		
12	MERV8 filters kit	SV66133	1	1	1	1	1	1	1	1	1	1	1	1	1	1	1	1	1	1
13	Door	SV66150	1	1	1	1	1	1	1	1	1	1	1	1	1	1	1	1	1	1
14	Exhaust damper	SV66143	1	1	1	1	1	1	1	1	1	1	1	1	1	1	1	1	1	1
15	Separator WE with thermistor	SV66149																1	1	
*	Hardware kit	SV66146	1	1	1	1	1	1	1	1	1	1	1	1	1	1	1	1	1	1
*	Fuse for PCB	SV66147	1	1	1	1	1	1	1	1	1	1	1	1	1	1	1	1	1	1
*	½" hose	SV00592	1	1	1	1	1	1	1	1	1	1	1	1	1	1	1	1	1	1

REPLACEMENT PARTS AND REPAIRS
 In order to ensure your ventilation unit remains in good working condition, you must use the manufacturer's genuine replacement parts only. The manufacturer's genuine replacement parts are specially designed for each unit and are manufactured to comply with all the applicable certification standards and maintain a high standard of safety. Any third party replacement part used may cause serious damage and drastically reduce the performance level of your unit, which will result in premature failing. The manufacturer recommends to contact a certified service depot for all replacement parts and repairs.

* Not shown.

** See next page to get the part number that corresponds to the ventilation unit model.

7. SERVICE PARTS (CONT'D)

ELECTRONIC ASSEMBLY PART NUMBER	VENTILATION UNIT MODEL																		
	A/V110H65RS	A/V110H65RT	A/V130H65RS	A/V130H65RT	A/V160H65RS	A/V160H65RT	A/V150H75NS	A/V150H75NT	A/V160H75RS	A/V160H75RT	A/V130E65RS	A/V130E65RT	A/V160E65RS	A/V160E65RT	A/V150E75NS	A/V150E75NT	A/V160E75RS	A/V160E75RT	
SV66144-01	X																		
SV66144-02		X																	
SV66144-03			X																
SV66144-04				X															
SV66144-05					X														
SV66144-06						X													
SV66144-07							X												
SV66144-08								X											
SV66144-09									X										
SV66144-10										X									
SV66144-11											X								
SV66144-12												X							
SV66144-13													X						
SV66144-14														X					
SV66144-15															X				
SV66144-16																X			
SV66144-17																	X		
SV66144-18																		X	

8. INSTALLER'S TROUBLESHOOTING

⚠ WARNING

A few diagnosis procedures may require the unit to be in operation while proceeding. Be careful with moving and/or live parts.

ERROR	DESCRIPTION	SOLUTION
01	Supply damper range	<p>STEP 1: Unplug unit, inspect the damper system, remove any undesirable obstacle or dirt (filters and core may have to be removed to access the damper system). Plug unit.</p> <p>If STEP 1 did not fix the problem, perform STEP 2: Open electrical compartment, check if connector J5 (white) is well inserted, check for any loose wires.</p> <p>If STEP 2 did not fix the problem, perform STEP 3: If the damper is not moving at all, unplug J7 (red) from the electronic assembly, connect the white damper system connector into J7. If the damper moves (but the system still shows an error), the electronic assembly must be replaced. Otherwise, replace the damper system.</p>
02	Supply damper timeout	
03	Supply damper	
05	Exhaust damper range	<p>STEP 1: Unplug unit, inspect the damper system, remove any undesirable obstacle or dirt (filters and core may have to be removed to access the damper system). Plug unit.</p> <p>If STEP 1 did not fix the problem, perform STEP 2: Open electrical compartment, check if connector J7 (red) is well inserted, check for any loose wires.</p> <p>If STEP 2 did not fix the problem, perform STEP 3: If the damper is not moving at all, unplug J5 (white) from the electronic assembly, connect the white damper system connector into J5. If the damper moves (but the system still shows an error), the electronic assembly must be replaced. Otherwise, replace the damper system.</p>
06	Exhaust damper timeout	
07	Exhaust damper	
09	Recirculation damper range	<p>STEP 1: Unplug unit, inspect the damper system, remove any undesirable obstacle or dirt (filters and core may have to be removed to access the damper system). Plug unit.</p> <p>If STEP 1 did not fix the problem, perform STEP 2: Open electrical compartment, check if connector J6 (blue) is well inserted, check for any loose wires.</p> <p>If STEP 2 did not fix the problem, perform STEP 3: If the damper is not moving at all, unplug J5 (white) from the electronic assembly, connect the blue damper system connector into J5. If the damper moves (but the system still shows an error), the electronic assembly must be replaced. Otherwise, replace the damper system.</p>
10	Recirculation damper timeout	
11	Recirculation damper	
22	Supply airflow	<p>STEP 1: Perform a visual inspection of the supply damper system. Clean filters, distribution registers and outside supply hood. Inspect ducting to ensure it is not squeezed or bent.</p> <p>If STEP 1 did not fix the problem, perform STEP 2: Remove ducting of the supply path. On the LCD screen, select MAX to check if the unit is able to reach the selected flow. If so, review the ducting path.</p> <p>If STEP 2 did not fix the problem, perform STEP 3: On the LCD screen, select the MIN and MAX flow setting values then reset the unit. MAX flow value will display on the LCD screen. If MAX flow is above desired MAX flow, set MAX and MIN flows.</p> <p>If STEP 3 did not fix the problem, perform STEP 4: Replace the supply blower and repeat STEP 3.</p> <p>If STEP 4 did not fix the problem, perform STEP 5: Replace the electronic assembly.</p>
23	Supply motor (drive over current)	<p>STEP 1: Unplug/plug unit.</p> <p>If STEP 1 did not fix the problem, perform STEP 2: Remove core and clear the ventilation wheel from any dirt or obstacles.</p> <p>If STEP 2 did not fix the problem, perform STEP 3: Disconnect J2 (white) and connect a spare blower system. If it works, replace supply blower.</p> <p>If STEP 3 did not fix the problem, perform STEP 4: Replace the electronic assembly.</p>
27	Supply motor (drive foc duration)	
28	Supply motor (drive speed feedback)	
29	Supply motor (startup)	
24	Supply motor (drive over voltage)	
25	Supply motor (drive under voltage)	<p>STEP 1: Unplug/plug unit. Under and over voltage may be detected with severe in-house power supply fluctuation and stop the motor for protection.</p> <p>If STEP 1 did not fix the problem, perform STEP 2: Replace the electronic assembly.</p>

8. INSTALLER'S TROUBLESHOOTING (CONT'D)

ERROR	DESCRIPTION	SOLUTION
26	Supply motor (drive over temp)	STEP 1: Validate if the air exchanger is exposed to ambient temperatures within the operating limits (see p. 4) If STEP 1 did not fix the problem, perform STEP 2: Replace the electronic assembly.
32	Exhaust airflow	STEP 1: Perform a visual inspection of the exhaust damper system. Clean filters, distribution registers and outside supply hood. Inspect ducting to ensure it is not squeezed or bent. If STEP 1 did not fix the problem, perform STEP 2: Remove ducting of the supply path. On the LCD screen, select MAX to check if the unit is able to reach the selected flow. If so, review the ducting path. If STEP 2 did not fix the problem, perform STEP 3: On the LCD screen, select the MIN and MAX flow setting values then reset the unit. MAX flow value will display on the LCD screen. If MAX flow is above desired MAX flow, set MAX and MIN flows. If STEP 3 did not fix the problem, perform STEP 4: Replace the exhaust blower and repeat STEP 3. If STEP 4 did not fix the problem, perform STEP 5: Replace the electronic assembly.
33	Exhaust motor (drive over current)	STEP 1: Unplug/plug unit. If STEP 1 did not fix the problem, perform STEP 2: Remove core and clear the ventilation wheel from any dirt or obstacles.
37	Exhaust motor (drive foc duration)	If STEP 2 did not fix the problem, perform STEP 3: Disconnect J3 (red) and connect a spare blower system. If it works, replace exhaust blower.
38	Exhaust motor (drive speed feedback)	If STEP 3 did not fix the problem, perform STEP 4: Replace the electronic assembly.
39	Exhaust motor (startup)	
34	Exhaust motor (drive over voltage)	STEP 1: Unplug/plug unit. Under and over voltage may be detected with severe in-house power supply fluctuation and stop the motor for protection.
35	Exhaust motor (drive under voltage)	If STEP 1 did not fix the problem, perform STEP 2: Replace the electronic assembly.
36	Exhaust motor (drive over temp)	STEP 1: Validate if the air exchanger is exposed to ambient temperatures within the operating limits (see p. 4) If STEP 1 did not fix the problem, perform STEP 2: Replace the electronic assembly.
40	Outside air thermistor	STEP 1: Check if thermistor is well connected in connector J7A. If STEP 1 did not fix the problem, perform STEP 2: Disconnect connector J7A and check if the measured resistance (thermistor connector) is within 5 Kohms to 120 Kohms. If outside the range, replace the thermistor. If STEP 2 did not fix the problem, perform STEP 3: Replace the electronic assembly.
41	Distribution air thermistor	STEP 1: Check if thermistor is well connected in connector J7B. If STEP 1 did not fix the problem, perform STEP 2: Disconnect connector J7B and check if the measured resistance (thermistor connector) is within 5 Kohms to 120 Kohms. If outside the range, replace the thermistor. If STEP 2 did not fix the problem, perform STEP 3: Replace the electronic assembly.
42	PCBA thermistor fault	STEP 1: Replace the electronic assembly.
43	PCBA temperature over limit	STEP 1: Validate if the air exchanger is exposed to ambient temperatures within the operating limits (see p. 4) If STEP 1 did not fix the problem, perform STEP 2: Replace the electronic assembly.
50	Wall control communication lost	STEP 1: Unplug unit, inspect wires, plug unit. If STEP 1 did not fix the problem, perform STEP 2: Remove wall control from the wall installation and test with a short cable. If it works, bring a new cable to the wall installation location. If STEP 2 did not fix the problem, perform STEP 3: Test the air exchanger with a spare wall control. If it works, replace the wall control. If STEP 3 did not fix the problem, perform STEP 4: Replace the electronic assembly.
51	Wall control sensor	STEP 1: Unplug unit, inspect wires, plug unit. If STEP 1 did not fix the problem, perform STEP 2: Replace the wall control.
60	Protection mode	STEP 1: Perform general inspection of the unit (dampers, core, filters).

8. INSTALLER'S TROUBLESHOOTING (CONT'D)

WARNING	DESCRIPTION	SOLUTION
22	Supply airflow	<p>STEP 1: Perform a visual inspection of the supply damper system. Clean filters, distribution registers and outside supply hood. Inspect ducting to ensure it is not squeezed or bent.</p> <p>If STEP 1 did not fix the problem, perform STEP 2: Remove ducting of the supply path. On the LCD screen, select MAX to check if the unit is able to reach the selected flow. If so, review the ducting path.</p> <p>If STEP 2 did not fix the problem, perform STEP 3: On the LCD screen, select the MIN and MAX flow setting values then reset the unit. MAX flow value will display on the LCD screen. If MAX flow is above desired MAX flow, set MAX and MIN flows.</p> <p>If STEP 3 did not fix the problem, perform STEP 4: Replace the supply blower and repeat STEP 3.</p> <p>If STEP 4 did not fix the problem, perform STEP 5: Replace the electronic assembly.</p>
32	Exhaust airflow	<p>STEP 1: Perform a visual inspection of the exhaust damper system. Clean filters, distribution registers and outside supply hood. Inspect ducting to ensure it is not squeezed or bent.</p> <p>If STEP 1 did not fix the problem, perform STEP 2: Remove ducting of the supply path. On the LCD screen, select MAX to check if the unit is able to reach the selected flow. If so, review the ducting path.</p> <p>If STEP 2 did not fix the problem, perform STEP 3: On the LCD screen, select the MIN and MAX flow setting values then reset the unit. MAX flow value will display on the LCD screen. If MAX flow is above desired MAX flow, set MAX and MIN flows.</p> <p>If STEP 3 did not fix the problem, perform STEP 4: Replace the exhaust blower and repeat STEP 3.</p> <p>If STEP 4 did not fix the problem, perform STEP 5: Replace the electronic assembly.</p>

9. MAINTENANCE

⚠ WARNING

Dangerous voltage. During maintenance and repairs, the unit must always be unplugged. We take great care to minimize sharp edges; however, please proceed with caution when handling all components. When cleaning the unit, it is recommended to wear safety glasses and gloves.

9.1 QUARTERLY

1. Disconnect power cord.
2. The door of this unit is hinged and maintained closed by 2 latches. Open them and set aside.
3. Clean the inside of the door with a damp cloth.
4. Clean filters:
 - Remove filters.
 - Vacuum to remove most of the dust.
 - Wash with a mixture of warm water and mild soap. You may add bleach if you wish to disinfect (one tablespoon per gallon). Rinse thoroughly. Shake filters to remove excess water and let dry.
5. Clean the condensing tray with a damp cloth.
6. Check the exterior air intake hood:

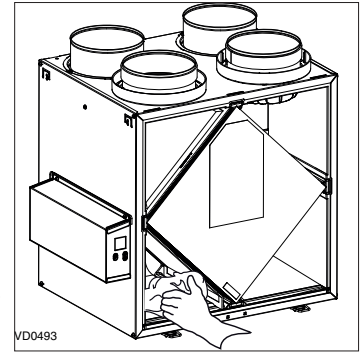

CAUTION

A blocked air vent, even partially, can cause the unit to malfunction.

- Make sure there are no leaves, twigs, ice or snow that could be drawn into the vent.
 - Clean if necessary.
7. Reassemble the components. Pay special attention to the filters by making sure that they are engaged in their slots.
 8. Rotate the blower wheels by hand. If one of the wheels does not rotate easily, contact your installer.
 9. Close the unit door and reconnect power supply.
 10. Reset filters, if required. If using an optional main wall control (DEHUMIDISTAT OR AUTOMATIC), press on the INT/AUTO button for 5 seconds to reset the filters. If using the ADVANCED optional main wall control, follow the instructions on the touch screen.

MERV8 FILTER INCLUDED

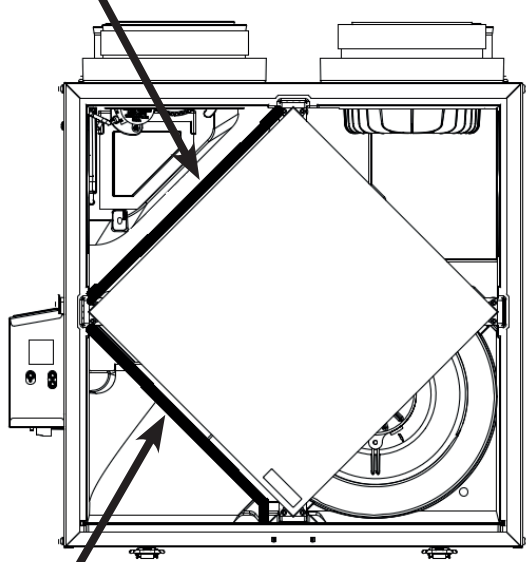

VD0494

EXHAUST FILTER INCLUDED

OPTIONAL MERV13 FILTER (EXHAUST FILTER NOT INCLUDED)

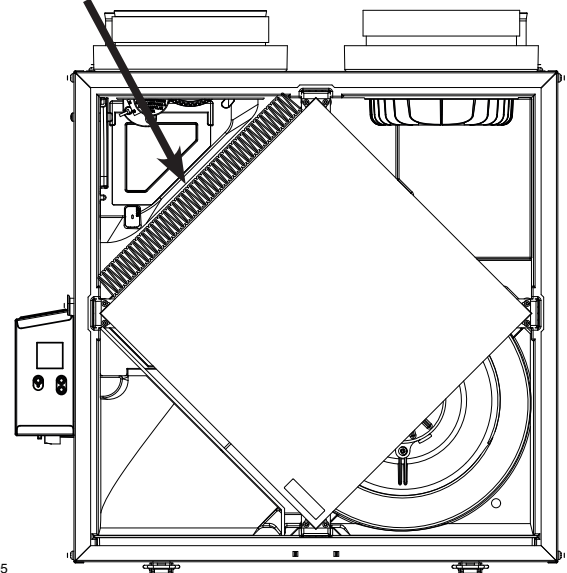

VD0495

NOTE: The optional MERV13 filter replaces the MERV8 filter.

9. MAINTENANCE (CONT'D)

9.2 ANNUAL (AT FALL)

- Repeat steps 1 to 6 from the previous section and continue with the following steps:

CAUTION

- Handle the recovery core with care.

- Clean the recovery core:

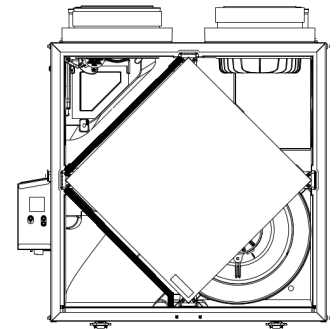

HRV MODELS	ERV MODELS
<ul style="list-style-type: none"> Remove the core. Let it soak in a mixture of cold or lukewarm water and mild soap (dishwashing liquid). Rinse thoroughly. Shake the core to remove excess water and let it dry. 	Remove the dust on the core using a vacuum cleaner and a soft brush attachment. CAUTION: DO NOT SOAK THE ENERGY RECOVERY CORE IN WATER

- Clean the blower assemblies. Do not disassemble the blower assemblies.
- Remove the dust using a vacuum cleaner with a soft brush attachment.
- Reassemble the components.
- Reconnect power supply.

10. USER'S TROUBLESHOOTING

Contact customer service at 1-800-567-3855 for any unresolved issue.

PROBLEM	TRY THIS
1. Nothing works.	<ul style="list-style-type: none"> See if the unit is plugged in. See if the unit is receiving power from the house circuit breaker or fuse.
2. Noisy unit.	<ul style="list-style-type: none"> Clean the unit (see Section 9). If the problem is not solved, contact your installer.
3. Condensation inside windows under cold weather conditions.	<ul style="list-style-type: none"> Operate the unit at MAX speed during activities generating excess humidity (family gatherings, extra cooking, etc.). Leave curtains half-open to allow air circulation. Store all firewood in a closed room with a dehumidifier or in a well ventilated room, or store the wood outdoors. Keep the temperature in your house above 18°C (64°F).
4. Humidity inside under hot/humid weather conditions.	<ul style="list-style-type: none"> Operate the unit in MIN speed. Temporarily switch to INT mode (if available). Use a dehumidifier.
5. Air too dry.	<ul style="list-style-type: none"> Operate the unit at MIN speed. Temporarily switch to INT mode (if available). Temporarily use a humidifier.
6. Air too cold at the air supply register.	<ul style="list-style-type: none"> Make sure the outdoor hoods are not blocked. Operate the unit at MIN speed. Install a duct heater (contact your installer).

11. WARRANTY

This ventilation unit is a high quality product, built and packaged with care. The manufacturer warrants to the original purchaser of its product, that such products will be free from defects for the period stated below, from date of original purchase. For all units, the warranty covers parts only against any operational defect. This 5-year warranty is subject to performance of the core maintenance according to recommendations in this manual. The heat recovery core (HRV) has a limited lifetime warranty, and the energy recovery core (ERV) has a 5-year warranty. If any defect should occur, we urge you to read the user guide carefully. If the problem persists, observe the following rules:

RULES TO FOLLOW

If the unit is defective, contact your ventilation contractor (see address on your manual's cover page). The contractor will determine with you the reason for the defect, and if needed, do the replacement or repair. If ever it is impossible to reach your ventilation contractor, call 1-800-567-3855 (in North America); the personnel will be pleased to give you the phone number of a distributor or a service center near you.

REPLACEMENT PARTS AND REPAIR

In order to ensure your ventilation unit remains in good working condition, you must use the manufacturer's genuine replacement parts only. The manufacturer's genuine replacement parts are specially designed for each unit and are manufactured to comply with all the applicable certification standards and maintain a high standard of safety. Any third party replacement part used may cause serious damage and drastically reduce the performance level of your unit, which will result in premature failing. The manufacturer also recommends that you contact a service depot certified by the manufacturer for all replacement parts and repair.

BILL OF PURCHASE

No replacement or repair covered by the warranty will be carried out unless the unit is accompanied by a copy of the original bill of purchase. Please retain your original.

MISCELLANEOUS COSTS

In each case, the labor costs for the removal of a defective part and/or installation of a compliant part will not be covered by the manufacturer.

CONDITIONS AND LIMITATIONS

These units are created for residential use only and must be used in a building as defined below:

Building: All structures zoned and/or erected for the act, process or art of human or animal habitation and/or the storage or warehousing of goods.

Residential use: Dwelling, lodging, suite: Building, or part of a building, intended to act as either the domicile to one or several people which can include general sanitary, food consumption and rest facilities. Buildings of only one room or a group of rooms including those occupied by a tenant or owner; comprise the lodgings, the individual rooms of the motels, hotels, rooming/lodging houses, boarding/half-way/foster homes, dormitories, and suites, as well as the stores and the business establishments constituted by only one room in a dwelling.

Commercial use: Agricultural establishment, commercial establishment for assembly, care, or detention: Building or part of a building that does not contain a dwelling, situated on land dedicated to agriculture or farming and used primarily to shelter animals, or for the production, the storage or the treatment of agricultural or horticultural products or animal food. Building or part of a building, used for the display or retail of goods, professional or personal services, or commodities. Building, or part of a building used by persons gathering for civic activities, religious or political assembly, tourism, educational/vocational training, recreation or the consumption of food or drink. Building, or part of a building used to shelter persons of impaired physical or psychological states, persons requiring palliative care or medical treatments, or persons for reasons out of their control, cannot escape harm or threat of danger autonomously.

Industrial use: Building, or part of a building, used for the assembly, the manufacture, the creation, the treatment, the repair or the storage of products and combustible materials and that contain fuels that when ignited or exploded in sufficient quantity may constitute a risk of fire.

The above warranty applies to all cases where the damage is not a result of poor installation, improper use, mistreatment or negligence, acts of God, or any other circumstances beyond the control of the manufacturer. Furthermore, the manufacturer will not be held responsible for any bodily injury or damage to personal property or real estate, whether caused directly or indirectly by the unit. This warranty supersedes all prior warranties.