

# Victaulic® FireLock NXT™ Dry Valve

## Series 768N

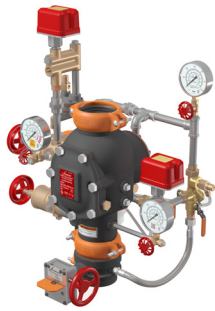

Patented

### 1.0 PRODUCT DESCRIPTION

#### Available Sizes:

- 1 ½ – 8" /40 – 200 mm

#### Pressure Class:

- Up to 300 psi/2068 kPa/20 Bar

#### Minimum Air Pressure:

- 13 psi/90 kPa/.90 Bar

#### Actuation Options:

- Series 776 Low Pressure Actuator
- Optional: Series 746-LPA Dry Accelerator

#### Valve Configurations:

- Bare
- Pre-trimmed: Completely assembled with all necessary trim components.
- Vic-Quick Riser: Pre-trimmed and includes:
  - Shut Off Valve (1 ½"/40 mm: Series 728 Ball Valve, 2" – 8"/50 – 200 mm: Series 705 FireLock Butterfly Valve)
  - Pre-set high or low air and alarm pressure switches
  - Drain kit
- Fire-Pac Series 745 (refer to Victaulic [submittal 30.23](#))

#### Pipe Preparation:

- Victaulic Original Groove System

#### Application/Media:

- For use on fire protection systems only.

**ALWAYS REFER TO ANY NOTIFICATIONS AT THE END OF THIS DOCUMENT REGARDING PRODUCT INSTALLATION, MAINTENANCE OR SUPPORT.**

System No.		Location	
Submitted By		Date	

Spec Section		Paragraph	
Approved		Date	

## 2.0 CERTIFICATION/LISTINGS



**NOTE**

- CCC approval for DN80, DN100, DN150, DN200.

## 3.0 SPECIFICATIONS - MATERIAL

**Body:** Ductile iron conforming to ASTM A536, grade 65-45-12.

**Clapper:** Aluminum bronze UNS-C95500

**Latch:** Aluminum bronze UNS-C95500

**Shafts:** Stainless 17-4

**Clapper Seal:** Peroxide cured EPDM, ASTM D2000

**Bushings/Seat O-rings:** Nitrile

**Springs:** Stainless Steel (300 Series)

**Diaphragm:** Peroxide cured EPDM with fabric reinforcement

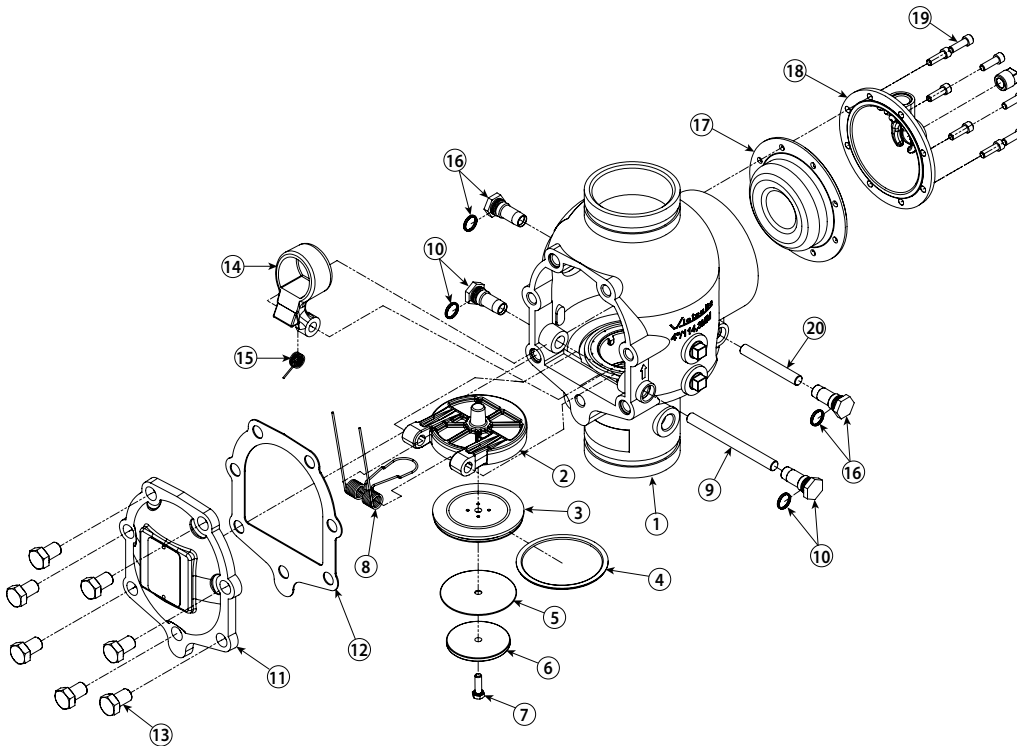

The 1½-inch/48.3-mm and 2-inch/60.3-mm valve sizes contain washers under the heads of the cover plate bolts.

Item	Description
1	Valve Body
2	Clapper
3	Clapper Seal
4	Seal Ring
5	Seal Washer
6	Seal Retaining Ring
7	Seal Assembly Bolt
8	Clapper Spring

Item	Description
11	Cover Plate
12	Cover Plate Gasket
13	Cover Plate Bolts
14	Latch
15	Latch Spring
16	Latch Spring Bushing and O-Ring (Qty. 2)
17	Diaphragm
18	Diaphragm Cover

Item	Description
9	Clapper Shaft
10	Clapper Shaft Bushing and O-Ring (Qty. 2)

Item	Description
19	Diaphragm Cover Cap Screws (Qty. 8)
20	Latch Shaft

### 3.0 SPECIFICATIONS – MATERIAL (Continued)

**Standard Trim Package:**

- Series 776 Low Pressure Actuator – The Series 776 Low Pressure Actuator is pneumatically actuated and requires only 13 psi/90 kPa minimum air pressure, regardless of the system supply pressure. This actuator allows the system to operate with a low air or gas pressure of 7 psi/48 kPa.
- All required pipe nipples and fittings - standard galvanized finish
- All standard trim accessories
- All required gauges

**Optional Trim Package:** Black Trim for Foam Systems – If the valve is intended for use in a foam system, black trim must be ordered, per NFPA requirements. Specify this requirement on the order.

**Optional Accessories:**

**Alarm Pressure Switch** – Alarm Pressure Switches are designed to activate electrical alarms and control panels when a sustained flow of water occurs (such as with an open sprinkler). Included in VQR trim.

**Air Supervisory Pressure Switch** – Air Pressure Supervisory Switches are used to monitor low and high system air pressure and are factory pre-set. Included in VQR trim.

**Series 746-LPA Dry Accelerator** – The Series 746-LPA Dry Accelerator is required when the Series 768N Dry Valve is installed in large systems to improve response time. Refer to Victaulic submittal 30.64.

**Series 760 Water Motor Alarm** – The Series 760 Water Motor Alarm is a mechanical device that sounds when a sustained flow of water occurs (such as with an open sprinkler). Refer to Victaulic submittal 30.32.

**Series 75B Supplemental Alarm Device** – The Series 75B Supplemental Alarm Device is designed to provide a continuous alarm for systems equipped with a mechanical device. Refer to Victaulic submittal 30.33.

**Series 75D Water Column Kit** – The Series 75D Water Column Kit is designed to minimize residual water in the riser from collecting above the clapper. Refer to Victaulic submittal 30.34.

**Air Supply System** – The air supply system contains all components for establishing and maintaining air in the system. The compressor, low-pressure alarms, ball valves, and required trim are included in the air supply system.

**Air Compressor** (See page 6 for more on the Victaulic Series 7C7 Compressor Package)

**Air Maintenance Trim Assembly**

**Fire Alarm Control Panels**

**Drain Connection Kit** – Included in VQR option.

### 3.0 SPECIFICATIONS – MATERIAL (Continued)

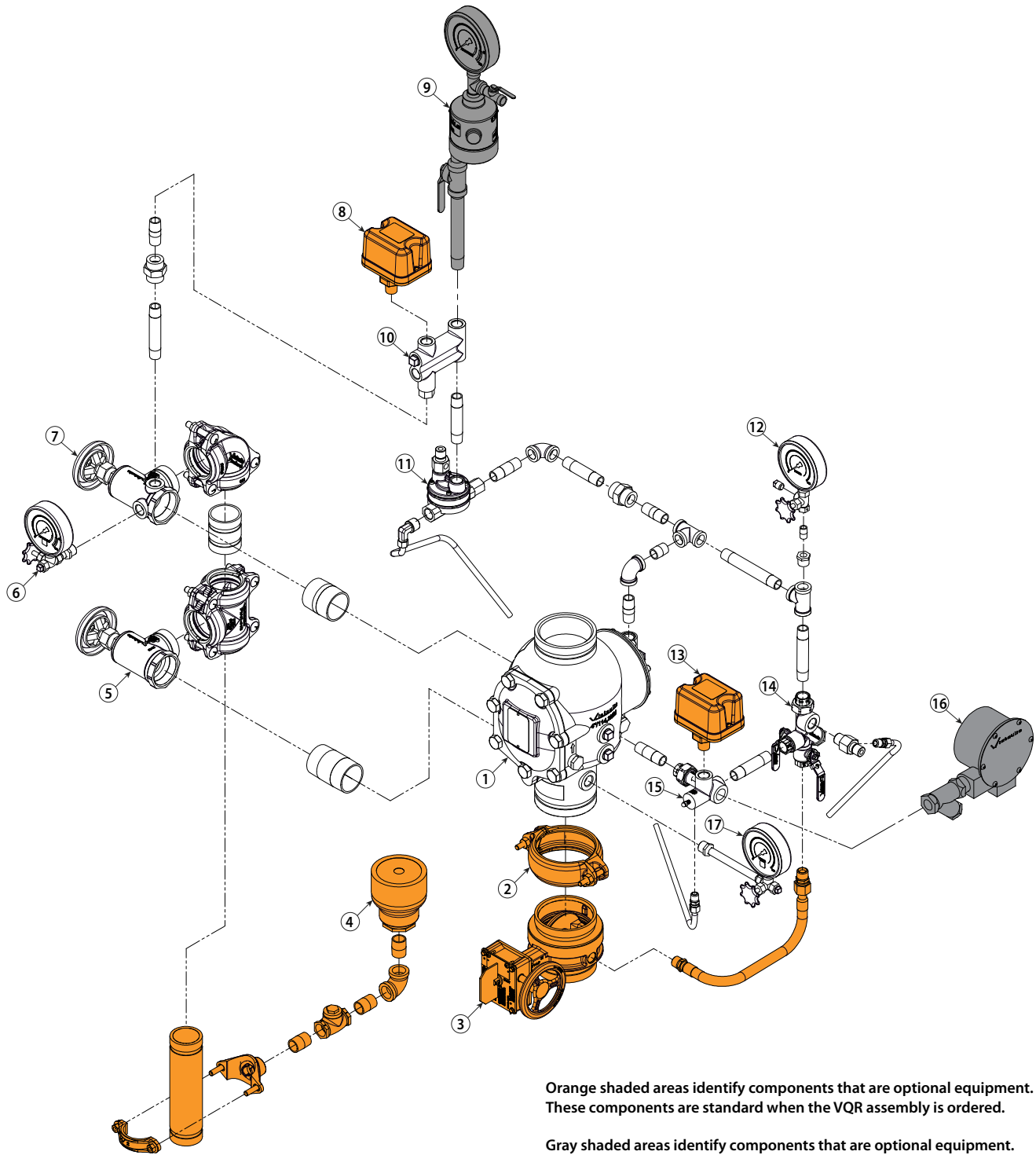

## 4.0 DIMENSIONS

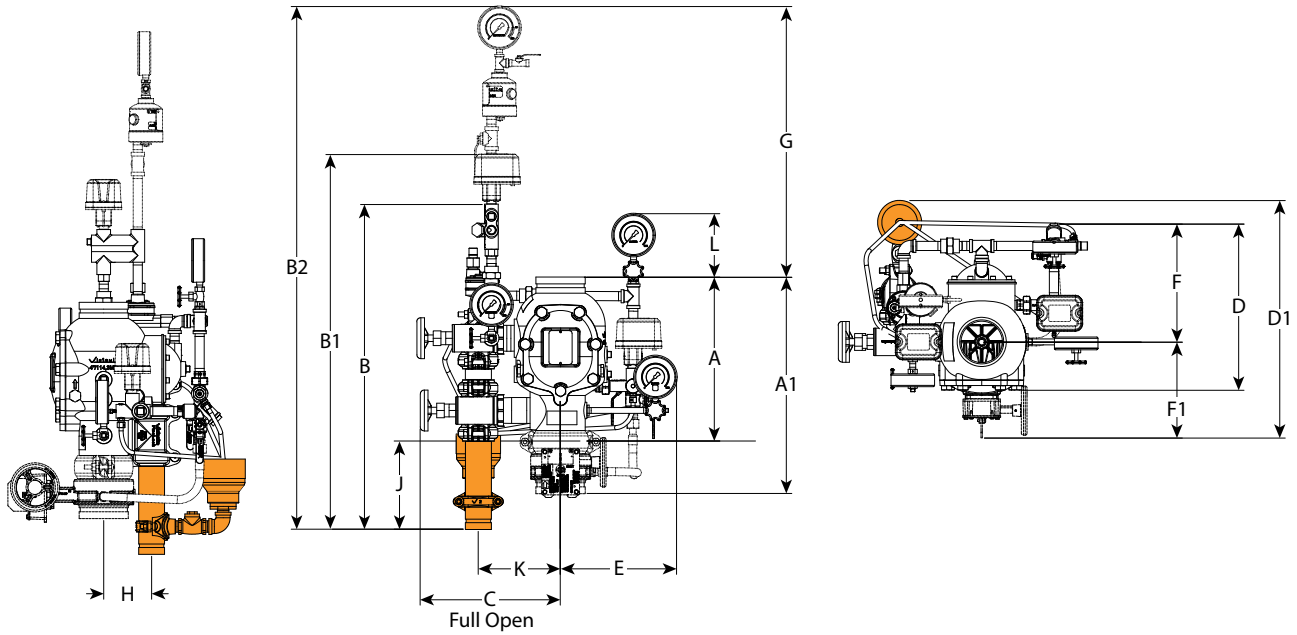

Nominal Size	Dimensions																Weight Each	
	A	A1	B	B1	B2	C	D	D1	E	F	F1	G	H	J	K	L	Without Trim	With Trim
	inches DN	inches mm	inches mm	inches mm	inches mm	inches mm	inches mm	inches mm	inches mm	inches mm	inches mm	inches mm	inches mm	inches mm	inches mm	inches mm	lbs kg	lbs kg
1 1/2 DN40	9.00 228.60	16.37 415.80	27.75 705	32.25 819	46.00 1168	10.25 260	13.00 330	16.25 413	9.00 229	10.00 254	5.50 140	27.25 692	3.25 83	10.25 260	6.00 152	8.25 210	16.7 7.6	43.0 19.5
2 DN50	9.00 228.60	13.83 351.28	27.75 705	32.25 819	46.00 1168	10.00 254	13.00 330	16.50 419	9.00 229	10.00 254	6.75 171	27.00 686	3.25 83	10.25 260	6.00 152	8.75 222	17.0 7.7	43.0 19.5
2 1/2 76.1 mm	12.61 320.29	16.51 419.35	29.50 749	34.25 870	47.75 1213	12.50 318	14.00 356	18.00 457	9.50 241	10.00 254	8.00 203	25.50 648	4.00 102	9.75 248	6.50 165	6.75 171	41.0 18.7	65.0 29.5
3 DN80	12.61 320.29	16.51 419.35	29.50 749	34.25 870	47.75 1213	12.50 318	14.00 356	18.00 457	9.50 241	10.00 254	8.00 203	25.50 648	4.00 102	9.75 248	6.50 165	6.75 171	41.0 18.7	66.0 29.9
4 DN100	15.03 381.76	19.85 504.19	30.25 768	34.75 883	48.25 1226	15.00 381	16.00 406	22.00 559	11.00 279	11.25 286	9.25 235	25.25 641	4.75 121	8.50 216	8.00 203	7.00 178	59.0 26.7	95.0 43.0
6 DN150	16.00 406.40	22.13 562.10	31.25 794	35.75 908	50.25 1276	15.25 387	17.00 432	28.75 730	11.00 279	11.75 298	11.75 298	25.50 648	4.50 114	8.25 210	8.25 210	7.25 184	80.0 36.2	116.0 52.6
8 DN200	17.50 444.50	23.02 584.71	33.00 838	37.75 959	51.25 1302	16.25 413	16.25 413	25.25 641	12.25 311	10.00 254	13.75 349	26.00 660	4.75 121	8.25 210	9.25 235	7.75 197	122.0 55.3	158.0 71.6

### NOTES

- The "A" dimension is the actual takeout dimension of the valve body.
- The "A1" dimension is the actual takeout dimension of the valve body with water supply main control valve.
- The "D1" dimension is not a fixed measurement. The drip cup can be rotated to provide more clearance at the back of the trim.
- Components shown as dotted lines denote optional equipment.

The recommended drain connection kit (shown in orange) is for reference and takeout dimensions. This drain connection comes standard when the VQR assembly is ordered. assembly is ordered.

## 5.0 PERFORMANCE

### Hydraulic Friction Loss

The chart below expresses the flow of water at 65°F/18°C through an open valve.

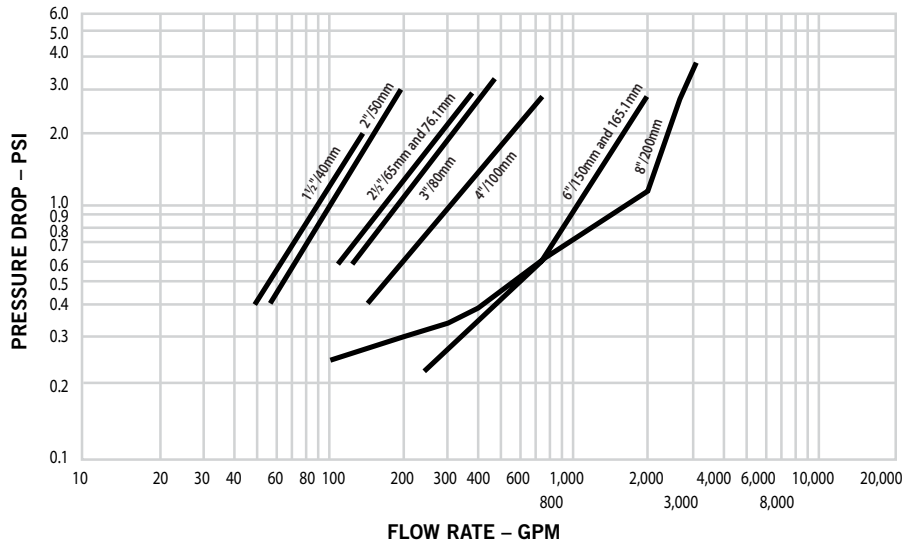

### Frictional Resistance

The chart below expresses the frictional resistance of Victaulic Series 768N FireLock NXT. Dry Valve in equivalent feet of straight pipe.

Nominal Size inches DN	Actual Outside Diameter inches mm	Equivalent Length of Pipe feet meters
1 1/2 DN40	1.900 48.3	3.00 0.914
2 DN50	2.375 60.3	9.00 2.743
2 1/2	2.875 73.0	8.00 2.438
76.1 mm	3.000 76.1	8.00 2.439
3 DN80	3.500 88.9	17.00 5.182
4 DN100	4.500 114.3	21.00 6.401
165.1 mm	6.500 165.1	22.00 6.706
6 DN150	6.625 168.3	22.00 6.706
8 DN200	8.625 219.1	50.00 15.240

### Cv Values:

Cv values for flow of water at +60°F/+16°C through a fully open valve are shown in the table below.

### Formulas for Cv values

$$\Delta P = Q^2 / C_v^2$$

$$Q = C_v \times \sqrt{\Delta P}$$

Where:

Flow Coefficient	Cv
Q (Flow)	GPM
ΔP (Pressure Drop)	psi

Valve Size		Full Open
Nominal Size inches DN	Actual Outside Diameter inches mm	Flow Coefficient Cv Kv
1 1/2 DN40	1.900 48.3	60 52.0
2 DN50	2.375 60.3	110 95.0
2 1/2	2.875 73.0	180 156.0
76.1 mm	3.000 76.1	180 156.0
3 DN80	3.500 88.9	200 173.0
4 DN100	4.500 114.3	350 302.8
165.1 mm	6.500 165.1	1000 865.0
6 DN150	6.625 168.3	1000 865.0
8 DN200	8.625 219.1	1500 1499.1

## 5.0 PERFORMANCE (Continued)

---

### Air Supply Requirements

- Minimum: 13 psi/90 kPa/.9 Bar regardless of the system water pressure
- Maximum Recommended: 18 psi/124 kPa/1.24 Bar
- Multiple Series 768N FireLock NXT Dry Valves with a common air supply:
  - Isolate systems with a Victaulic spring –loaded, soft-seated ball check valve to ensure air integrity and serviceability of each system.
- Sizing the compressor:
  - Engineer/system designer is responsible
  - Entire system must be charged to the required air pressure within 30 minutes to meet NFPA requirements
  - An oversized compressor will slow down or possibly prevent valve operation
  - Compressor filling the system too fast:
    - May be necessary to restrict the air supply
    - Ensure that air exhausted from an open sprinkler or manual release valve is not replaced by the air supply system as fast as it is exhausted
- Compressor Requirements
  - Base or Riser Mounted Compressors:
    - “On” or “low” pressure setting: 13 psi/90 kPa/.9 Bar
    - “Off” or “high” pressure setting: 18 psi/124 kPa/1.24 Bar
    - Victaulic Series 7C7 riser mounted and pre-set for pressure requirements (refer to Victaulic [submittal 30.22](#)).
    - If the compressor is not equipped with a pressure switch, the Series 757P Air Maintenance Trim Assembly with pressure switch should be installed (refer to Victaulic [submittal 30.36](#)).
  - Shop Air or Tank-Mounted Air Compressors:
    - Series 757 Regulated Air Maintenance Trim Assembly should be installed (refer to Victaulic [submittal 30.35](#))
    - 13 psi/90 kPa/.9 Bar should be used as the set point for the air regulator
    - The compressor cut-in (turn-on) pressure setting should be at least 5 psi/34kPa/34 Bar above the set point of the air regulator.
    - Exploded View Trim: Series 757 Regulated Air Maintenance Trim Assembly (refer to Victaulic [submittal 30.35](#))
- Compressor Requirements and settings for systems installed with series 746 or series 746-LPA dry accelerators
  - A tank-mounted air compressor with a Series 757 Regulated AMTA must be used to supply air to system installed with a Series 746 or Series 746-LPA Dry Accelerator.
  - In the event a compressor becomes inoperative, a properly sized tank-mounted air compressor provides the greatest protection, since air can be supplied continuously to the sprinkler system for an extended time period.

## 6.0 NOTIFICATIONS

### WARNING



- Read and understand all instructions before attempting to install, remove, adjust, or maintain any Victaulic piping products.
- Depressurize and drain the piping system before attempting to install, remove, adjust, or maintain any Victaulic piping products.
- Wear safety glasses, hardhat, and foot protection.

Failure to follow these instructions could result in death or serious personal injury and property damage.

## 7.0 REFERENCE MATERIALS

- [30.35: FireLock™ Air Maintenance Trim Assembly Series 757 Submittal](#)
- [30.36: FireLock™ Air Maintenance Trim Assembly Series 757P Submittal](#)
- [30.22: FireLock® Compressor Package Series 7C7 Submittal](#)
- [30.32: FireLock™ Water Motor Alarm Series 760 Submittal](#)
- [30.64: FireLock™ Dry Accelerator Series 746-LPA](#)
- [30.65: FireLock™ Low Pressure Actuator Series 776 Submittal](#)
- [I-768N: FireLock NXT™ Dry Valve Series 768N Installation Manual](#)

### User Responsibility for Product Selection and Suitability

Each user bears final responsibility for making a determination as to the suitability of Victaulic products for a particular end-use application, in accordance with industry standards and project specifications, as well as Victaulic performance, maintenance, safety, and warning instructions. Nothing in this or any other document, nor any verbal recommendation, advice, or opinion from any Victaulic employee, shall be deemed to alter, vary, supersede, or waive any provision of Victaulic Company's standard conditions of sale, installation guide, or this disclaimer.

### Intellectual Property Rights

No statement contained herein concerning a possible or suggested use of any material, product, service, or design is intended, or should be construed, to grant any license under any patent or other intellectual property right of Victaulic or any of its subsidiaries or affiliates covering such use or design, or as a recommendation for the use of such material, product, service, or design in the infringement of any patent or other intellectual property right. The terms "Patented" or "Patent Pending" refer to design or utility patents or patent applications for articles and/or methods of use in the United States and/or other countries.

### Note

This product shall be manufactured by Victaulic or to Victaulic specifications. All products to be installed in accordance with current Victaulic installation/assembly instructions. Victaulic reserves the right to change product specifications, designs and standard equipment without notice and without incurring obligations.

### Installation

Reference should always be made to the Victaulic installation handbook or installation instructions of the product you are installing. Handbooks are included with each shipment of Victaulic products, providing complete installation and assembly data, and are available in PDF format on our website at [www.victaulic.com](http://www.victaulic.com).

### Warranty

Refer to the Warranty section of the current Price List or contact Victaulic for details.

### Trademarks

*Victaulic* and all other Victaulic marks are the trademarks or registered trademarks of Victaulic Company, and/or its affiliated entities, in the U.S. and/or other countries.